

# WELDING CONSUMABLES CATALOG

## CATÁLOGO DE SUMINISTROS DE SOLDADURA

Disclaimer: Some products in this catalog may not be available to distributors. Please contact your account manager if any of these products are available in stock or through the Mill Department.







**TIG Torches**  
*See Page 28*

**Gouging**  
*See Page 23*

**MIG Guns**  
*See Page 4*



**BRIGHTON-BEST  
INTERNATIONAL**

 <h1>WARNING</h1>			<p>Read and follow the manufacturer's instructions, employer's safety practices and Material Safety Data Sheets (MSDS). Only qualified personnel should install, use or service this material and or equipment.</p>
 <p><b>ELECTRIC SHOCK</b> can kill.</p> <ul style="list-style-type: none"> <li>• Always wear dry insulating gloves.</li> <li>• Do not touch live electrical parts.</li> <li>• Always disconnect power source before hooking up or changing electrodes, nozzles and other parts.</li> </ul>	 <p><b>WELDING SPARKS</b> can cause fire or explosion.</p> <ul style="list-style-type: none"> <li>• Do not weld near flammable material.</li> <li>• Do not weld on closed containers.</li> <li>• Remove combustibles from the work area and / or provide a fire watch.</li> <li>• Avoid oily or greasy clothing as a spark may ignite them.</li> </ul>	 <p><b>LOUD NOISE</b> can damage hearing.</p> <ul style="list-style-type: none"> <li>• Always wear protective hearing devices to ensure protection when noise levels exceed OSHA standards.</li> </ul>	
 <p><b>FUMES AND GASES</b> can be hazardous to your health.</p> <ul style="list-style-type: none"> <li>• Keep your head out of the fumes.</li> <li>• Use enough ventilation or exhaust at the arc to keep fumes and gases from your breathing zone and the general area.</li> <li>• Fumes from welding and cutting can deplete air quality, cause injury or death. Always wear an air supplied respirator in confined areas or if breathing air is not safe.</li> </ul>	 <p><b>ARC RAYS</b> can injure eyes and burn skin.</p> <ul style="list-style-type: none"> <li>• Always wear correct eye, ear and body protection.</li> <li>• Always wear a welding helmet with the proper grade filter lens. Protect yourself and others from spatter arc flash rays by using protective screens, barriers and welding curtains.</li> <li>• Always wear protective gloves and clothing to cover exposed skin. This will aid in the prevention of arc and splatter burns.</li> </ul>		
<p>Read American National Standard Z49.1, "Safety in Welding, Cutting, and Allied Processes," available from American Welding Society, 8669 Doral Boulevard, Suite 130, Doral, FL 33166; OSHA Safety and Health Standards, available from U.S. Government Printing Office, Washington, DC 20402</p>			

 <h1>CUIDADO</h1>			<p>Lea y siga las instrucciones del fabricante, las prácticas seguras de su compañía y los datos de las Hojas de Seguridad del Producto. Solo personal calificado debe instalar, usar o dar servicio a este material y/o equipo.</p>
 <p><b>CHOQUES ELECTRICOS</b> pueden matar</p> <ul style="list-style-type: none"> <li>• Siempre use guantes secos aislantes.</li> <li>• No toque partes eléctricamente cargadas</li> <li>• Siempre desconecte la fuente de poder antes de instalar o cambiar electrodos, boquillas y otras partes</li> </ul>	 <p><b>CHISPAS DE SOLDADURA</b> pueden causar fuego o explosión.</p> <ul style="list-style-type: none"> <li>• No suelde cerca de material inflamable.</li> <li>• No suelde en lugares cerrados.</li> <li>• Retire combustibles del área de trabajo y/o coloque un detector de incendio.</li> <li>• Evite ropa con aceite o grasa pues una chispa puede encenderlas.</li> </ul>	 <p><b>RUIDO ALTO</b> puede dañar el oído.</p> <ul style="list-style-type: none"> <li>• Siempre use aparatos protectores de oído para asegurar protección cuando los niveles de ruido excedan los estándares OSHA</li> </ul>	
 <p><b>HUMOS Y GASES</b> pueden ser dañinos para su salud.</p> <ul style="list-style-type: none"> <li>• Mantenga su cabeza fuera de los humos.</li> <li>• Use suficiente ventilación o extracción desde el arco para evitar que los humos y gases lleguen a su zona de respiración y área en general.</li> <li>• Los humos de la soldadura y corte pueden terminar con la calidad del aire, causar lesiones o la muerte. Siempre use un respirador en áreas confinadas o si el aire que se respira no es seguro</li> </ul>	 <p><b>LOS RAYOS DEL ARCO</b> pueden dañar sus ojos y quemar su piel.</p> <ul style="list-style-type: none"> <li>• Siempre use la protección corecta de vista, oído y cuerpo</li> <li>• Siempre use una careta de soldadura con la sombra apropiada. Protéjase a usted y a otros de los rayos del arco y de la escoria usando pantallas protectoras, barreras y cortinas para soldadura.</li> <li>• Siempre use guantes protectores y ropa para cubrir la piel expuesta. Esto ayudará en la prevención de quemaduras por arco y escoria.</li> </ul>		
<p>Lea el Estándar Nacional Americano Z49.1, "Safety in Welding, Cutting, and Allied Processes," disponible en la Sociedad Americana de Soldadura, 8669 Doral Boulevard, Suite 130, Doral, FL 33166; los Estándares de Seguridad y Salud OSHA, disponibles en la Oficina de Impresión del Gobierno de E.U., Washington, DC 20402</p>			

Brighton-Best International is not affiliated with Lincoln®, Miller®, Tweco®, Bernard® or Tregaskiss®. The parts shown in this catalog are not genuine brand name parts and are manufactured for BBI. References to the above named brands, machines or part numbers are for convenience only.

Brighton-Best International no son afiliados con Lincoln®, Miller®, Tweco®, Bernard® o Tregaskiss®. Las piezas que se muestran en este catálogo no son piezas originales de la marca y se fabrican para BBI. Las referencias a las marcas arriba mencionadas, las máquinas o en parte los números son únicamente para su comodidad.

<b>MIG GUNS</b>	<b>4-13</b>
Build-a-Gun	4-5
160 Amp MIG Gun	6-7
280 Amp MIG Gun	8-9
400 Amp MIG Gun	10-11
400 Amp #4 MIG Gun	12-13
<b>MIG CONSUMABLES</b>	<b>14-20</b>
Tweco® Style Consumables	14-15
Bernard® Style Consumables	16-17
Tregaskiss® Style Consumables	18-19
TIPREFIT MIG Change-out	19
Miller® Style Consumables	20
<b>OXY-FUEL CUTTING TIPS</b>	<b>21-22</b>
<b>CARBON ARC GOUGING</b>	<b>23-24</b>
4000 Gouging Torch	23
Gouging Carbons Electrodes	24
<b>TUNGSTEN GRINDERS</b>	<b>25-26</b>
<b>TUNGSTEN ELECTRODES</b>	<b>27</b>
<b>TIG TORCHES &amp; PACKAGES</b>	<b>28-45</b>
Modular TIG Kits	28
150M Series Torches & Torch Packages	29
200M Series Torches & Torch Packages	30
225M Series Torches & Torch Packages	31
9 Series Torches & Torch Packages	32
9FMT Series Torches & Torch Packages	33
17 Series Torches & Torch Packages	34
17FMT Series Torches & Torch Packages	35
26 Series Torches & Torch Packages	36
26FMT Series Torches & Torch Packages	37
24 Series Torches & Torch Packages	38
24FMT Series Torches & Torch Packages	39
24W Series Torches & Torch Packages	40
22 Series Torches & Torch Packages	41
20 Series Torches & Torch Packages	42
18 Series Torches & Torch Packages	43
12 Series Torches & Torch Packages	44
27 Series Torches & Torch Packages	45
<b>TIG CONSUMABLES SET-UPS</b>	<b>46-47</b>
<b>TIG ACCESSORY PARTS</b>	<b>48-54</b>
Back Caps & Valves	48
Collets & Collet Bodies	48-49
Gas Lenses	49
Nozzles, Alumina	50
Nozzles, Lava	51
Accessory Kits	52
Power Cables & Hoses	53
Extension Kits & Hook-up Kits	54
<b>TIG HOOK-UP INSTALLATION</b>	<b>55-56</b>

<b>PISTOLA MIG</b>	<b>4-13</b>
Construir una Pistola	4-5
Pistola MIG 160A	6-7
Pistola MIG 280A	8-9
Pistola MIG 400A	10-11
Pistola MIG 400A #4	12-13
<b>CONSUMIBLES MIG</b>	<b>14-20</b>
Consumibles MIG Estilo Tweco®	14-15
Consumibles MIG Estilo Bernard®	16-17
Consumibles MIG Estilo Tregaskiss®	18-19
Cambio de MIG TIPREFIT®	19
Consumibles MIG Estilo Miller®	20
<b>BOQUILLA DE CORTE, OXIGAS</b>	<b>21-22</b>
<b>CARBÓN ARC GOUGING</b>	<b>23-24</b>
Antorcha para carbón y aire 4000	23
Electrodos de carbón	24
<b>AMOLADORA DE TUNGSTENO</b>	<b>25-26</b>
<b>ELECTRODOS DE TUNGSTENO</b>	<b>27</b>
<b>ANTORCHAS TIG Y ENSAMBLAJES DE ANTORCHA</b>	<b>28-45</b>
Kits Modulares TIG	28
Serie 150M antorchas y ensamblajes de antorcha	29
Serie 200M antorchas y ensamblajes de antorcha	30
Serie 225M antorchas y ensamblajes de antorcha	31
Serie 9 antorchas y ensamblajes de antorcha	32
Serie 9FMT antorchas y ensamblajes de antorcha	33
Serie 17 antorchas y ensamblajes de antorcha	34
Serie 17FMT antorchas y ensamblajes de antorcha	35
Serie 26 antorchas y ensamblajes de antorcha	36
Serie 26FMT antorchas y ensamblajes de antorcha	37
Serie 24 antorchas y ensamblajes de antorcha	38
Serie 24FMT antorchas y ensamblajes de antorcha	39
Serie 24W antorchas y ensamblajes de antorcha	40
Serie 22 antorchas y ensamblajes de antorcha	41
Serie 20 antorchas y ensamblajes de antorcha	42
Serie 18 antorchas y ensamblajes de antorcha	43
Serie 12 antorchas y ensamblajes de antorcha	44
Serie 27 antorchas y ensamblajes de antorcha	45
<b>CONFIGURACIONES DE CONSUMIBLES TIG</b>	<b>46-47</b>
<b>ACCESORIOS PARA TIG</b>	<b>48-54</b>
Tapas traseras y válvulas	48
Mordazas y portamordaza	48-49
Portamordaza de Gas lens	49
Boquillas alumina	50
Boquillas lava	51
Kits de accesorios	52
Cable de alimentación y mangueras	53
Kits de extensiones y kits de configuración	54
<b>INSTALACIÓN DE CONEXIÓN TIG</b>	<b>55-56</b>



- 1 - SELECT THE GUN AMPERAGE
- 2 - SELECT THE MACHINE CONNECTOR
- 3 - SELECT CONSUMABLE TYPE
- 4 - SELECT TRIGGER CONNECTOR

- 1 - SELECCIONAR EL AMPERAJE DE LA PISTOLA
- 2 - SELECCIONAR EL CONECTOR DE LA MÁQUINA
- 3 - SELECCIONAR EL TIPO DE CONSUMIBLE
- 4 - SELECCIONAR EL GATILLO DEL CONECTOR



3 - Select Consumable Type  
 Seleccione tipo de consumible

#	Part #	Description Descripción	1 Gun Tube Cuellos	2 Insulator Aisladora	3 Diffuser Difusor	4 Nozzle Boquilla	5 Contact Tip Puntas de contacto	Liner Sirga
6	MCK-TW2	Tweco® 280 A	25CT	—	52FN	23-50	14-35, 14-45	42-4045-15
	MCK-TW4	Tweco® 400 A	40CT	40CTI	54A	23-62	14-35, 14-45	44-3545-15
7	MCK-MR2	Miller® 280 A	25CTM	169-730	169-728, 169-729	169-724	000-068, 000-069	42-4045-15
8	MCK-TR2	Tregaskis® 280 A	25CTT	402-5	404-13	401-4-50	403-1-35, 403-1-45	42-4045-15
	MCK-TR4	Tregaskis® 400 A	40CTT	402-5	404-13	401-6-62	403-1-35, 403-1-45	44-3545-15
9	MCK-BR2	Bernard® 280 A	25CTB	4323R	4335	4392	7489, 7490	42-4045-15
	MCK-BR4	Bernard® 400 A	40CTB	4423R	4435	4591	7489, 7490	44-3545-15



### 1 - Select Amperage Seleccionar el amperaje

#	Part #	Description	Descripción
1	250153545	280 Amp Platform Gun	280 A pistola de plataforma
2	400153545	400 Amp Platform Gun	400 A pistola de plataforma

### 2 - Machine connector Conector de la máquina

#	Part #	Description	Descripción
3	25TC	Tweco® Style	Estilo Tweco®
4	25MC	Miller® Style	Estilo Miller®
5	25LC	Lincoln® Style	Estilo Lincoln®

See pin Selector chart Below / Vea la tabla de selección Abajo



### 4 - Trigger Connector Gatillo del conector

#	Part #	Description	Descripción
10	25MA	Miller® Style 4 Pin (included)	Estilo Miller® 4 Pin (incluido)
11	25LAC	Lincoln® Style 5 Pin (optional)	Estilo Lincoln® 5 Pin (opcional)

See pin Selector Guide Below / Ver pin Guía de selección Abajo

### Selector Chart Tabla de selección

Manufacturer Fabricante	Welding Machine or Wire Feeder Máquina de soldadura o alimentador de alambre	Machine Connector Conector de la máquina	Trigger Connector Gatillo del conector
Hobart®	•Beta-MIG 250/251	25TC	Included   incluido
	•Beta-MIG 1800 (500 Series) •IronMan™ 210/240	25MC	Included   incluido
	•Beta-MIG 2510 (500 Series) •Beta-MIG 2250 •IronMan™ 250, 275	25MC	Included   incluido
Miller®	•Millermatic® 90/120/130/130XP •Millermatic ® 140/150/175/180/185/ 211 •SideKick™ •SideKick™ XL •Miller® Challenger •Challenger 172 •Millermatic® DVI •Millermatic® Passport®	25MC	Included   incluido
	•Millermatic 200, 210, 212, 250, 250X, 251, 252 350/350P & Millermatic Vintage, 300 Axxess 300/450 •MigRunner Package CP-302, Delta-Fab System, Deltaweld 302, 452, Invision 456MP, 456P	25MC	Included   incluido
Lincoln®	•Power MIG® 200/215/255/255C/300 •Wire-Matic™ 255	25TC	Included   incluido
	•LN-7 Series, LN-742, LN-8, LN-9 Series LN-25	25LC	25LAC
	•Power Feed™ 10M/LN-10/DH-10/STT-10/LN-15 •Power Feed™ 15MLF-72/LF-74 Series	25TC	25LAC



# MIG GUNS

160 Amp Air-Cooled  
Available Guns & Setup Options

# PISTOLA MIG

Pistolas MIG 160A enfriadas por aire  
Pistolas & configuraciones disponibles



Pin Connector/Conector



Tweco®

Miller®



Euro

### Available MIG Guns

Part # Número de la parte	Wire Size Tamaño del cable	Length Longitud	Consumable Type Estilo de consumibles	Pin Connector Conector	Gun Type Tipo de pistola
135103035T	.030"-.035"/0.8mm-0.9mm	10' (3.0M)	Tweco®	Tweco®	MIG
135M103035M	.030"-.035"/0.8mm-0.9mm	10' (3.0M)	Miller®	Miller®	MIG
135103035M	.030"-.035"/0.8mm-0.9mm	10' (3.0M)	Tweco®	Miller®	MIG
135103035E	.030"-.035"/0.8mm-0.9mm	10' (3.0M)	Euro	Euro	MIG
135103545FC	.035"-.045"/0.9mm-1.2mm	10' (3.0M)	Tweco®	Tweco®	Flux core

### Pistolas MIG disponibles



#	Part#	Description	Descripción
Tweco® Style / Estilo Tweco®			
1	35-50	Diffuser	Difusor
Miller® Style / Estilo Miller®			
1A	169-716	Diffuser	Difusor

#	Part#	Description	Descripción	Size / Tamaño
Tweco® Style Contact Tip / Puntas de contacto Estilo Tweco®				
2	11-23	Standard	Estándar	.023" (0.6mm)
	11-30	Standard	Estándar	.030" (0.8mm)
	11-35	Standard	Estándar	.035" (0.9mm)
	11-45	Standard	Estándar	.045" (1.2mm)
2A	11T-23	Tapered	Ahusadas	.023" (0.6mm)
	11T-30	Tapered	Ahusadas	.030" (0.8mm)
	11T-35	Tapered	Ahusadas	.035" (0.9mm)
Miller® Style Contact Tips / Puntas de contacto Estilo Miller®				
2B	087-299	Standard	Estándar	.023" (0.6mm)
	000-067	Standard	Estándar	.030" (0.8mm)
	000-068	Standard	Estándar	.035" (0.9mm)
	000-069	Standard	Estándar	.045" (1.2mm)

#	Part#	Description	Descripción	Size / Tamaño
Tweco® Style Nozzles / Boquilla Estilo Tweco®				
3	21-37	Insulated 1/8" Recess	Aislado, 1/8" Empotrada	3/8"
	21-50	Insulated 1/8" Recess	Aislado, 1/8" Empotrada	1/2"
	21-50F	Insulated, Flush	Aislado, romo	1/2"
	21-62	Insulated 1/8" Recess	Aislado, 1/8" Empotrada	5/8"
	21T-37	Insulated, Tapered	Aislado, ahusadas	3/8"
3B	KP1939-1	Gasless Nozzle	Boquilla sin gas	
Miller® Style Nozzle / Boquilla Estilo Miller®				
4	169-715	Insulated, Flush	Aislado, romo	1/2"



# MIG GUNS

160 Amp Air-Cooled  
Parts Breakdown

# PISTOLA MIG

Pistolas MIG 160A enfriadas por aire  
Desglose de Partes

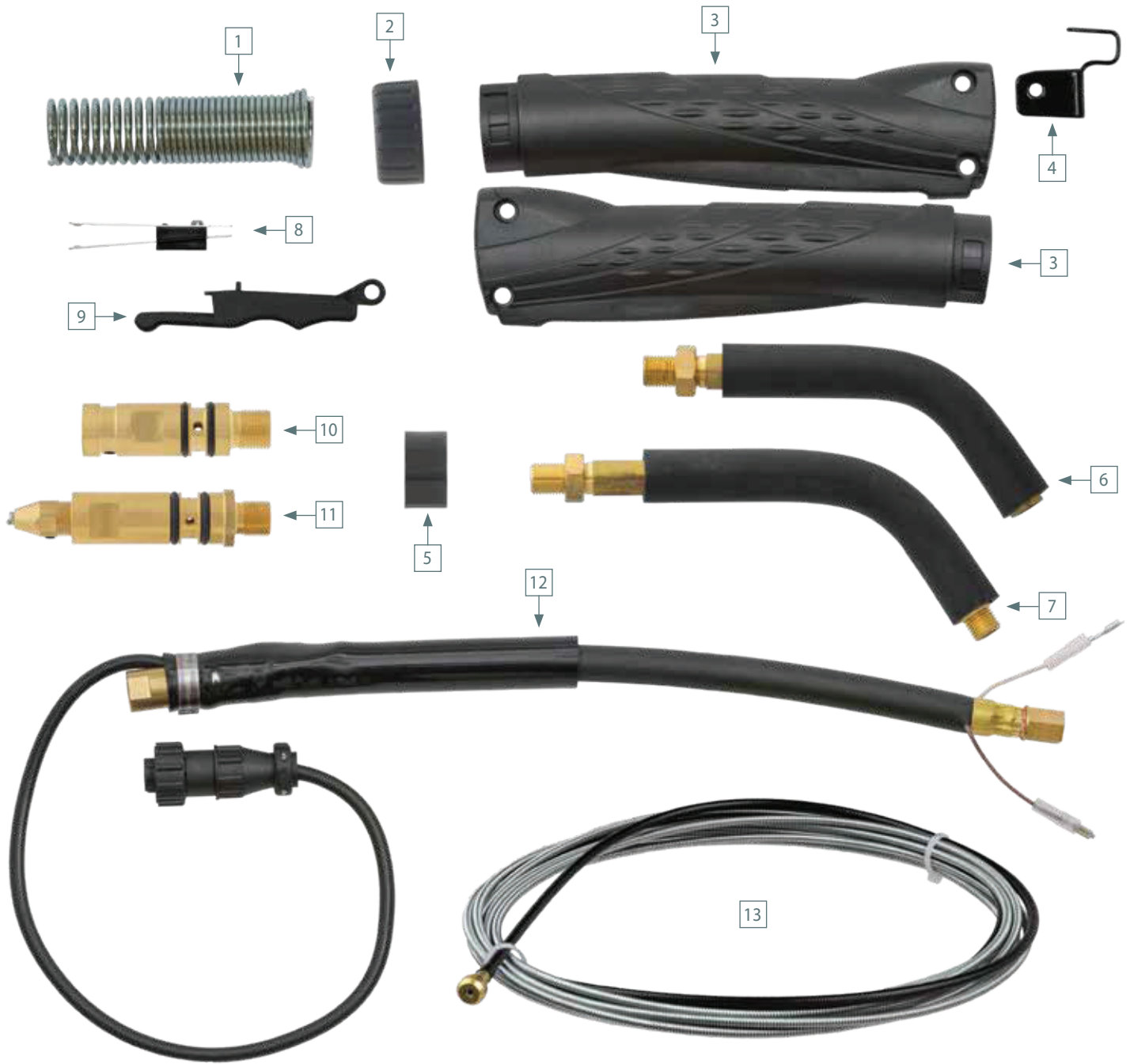

#	Part#	Description	Descripción	#	Part#	Description	Descripción
1	13SR	Strain Relief	Resorte para alivio de tensión	8	25TB	Trigger Blade	Gatillo del interruptor
2	13HR	Handle Locking Ring	Anillo de seguridad para empuñadura	9	25TR	Comfort Grip Trigger	Gatillo de agarre cómodo
3	13HD	Handle 2pcs w/Screws	Empuñadura 2pcs con tornillos	10	13TC	Connector (Tweco)	Conector (Tweco)
4	25GH	Gun Hanger	Gancho de la pistola	11	13MC	Connector (Miller)	Conector (Miller)
5	13BK	Tube Block	Bloque del tubo	12	13PC	Power Cable 10'	Cable de energía 10'
6	13CT	Conductor Tube Tweco	Cuello estilo Tweco	13	35-40-15	Liner (MIG)	Sirgas (MIG)
7	13CTM	Conductor Tube Miller	Cuello estilo Miller		45-40-15	Liner (Flux Core)	Sirgas (Flux Core)



**BRIGHTON-BEST  
INTERNATIONAL**

# MIG GUNS

280 Amp Air-Cooled  
Available Guns & Setup Options

# PISTOLA MIG

Pistolas MIG 280A enfriadas por aire  
Pistolas & configuraciones disponibles

Available MIG Guns

Part # Número de la parte	Wire Size tamaño del cable	Length Longitud	Consumable Type Estilo de consumibles	Pin Connector Conector	Trigger Connector Conector de gatillo
250153035T	.030"-.035"/0.8mm-0.9mm	15' (4.6M)	Tweco®	Tweco®	Miller®
250153545T	.035"-.045"/0.9mm-1.2mm	15' (4.6M)	Tweco®	Tweco®	Miller®
250M123035M	.030"-.035"/0.8mm-0.9mm	12' (3.7M)	Miller®	Miller®	Miller®
250M153035M	.030"-.035"/0.8mm-0.9mm	15' (4.6M)	Miller®	Miller®	Miller®
250123035M	.030"-.035"/0.8mm-0.9mm	12' (3.7M)	Tweco®	Miller®	Miller®
250153035M	.030"-.035"/0.9mm-1.2mm	15' (4.6M)	Tweco®	Miller®	Miller®
250153545M	.035"-.045"/0.9mm-1.2mm	15' (4.6M)	Tweco®	Miller®	Miller®
250153035L	.030"-.035"/0.8mm-0.9mm	15' (4.6M)	Tweco®	Lincoln®	Lincoln®
250153545L	.035"-.045"/0.9mm-1.2mm	15' (4.6M)	Tweco®	Lincoln®	Lincoln®
250153035L2	.030"-.035"/0.8mm-0.9mm	15' (4.6M)	Tweco®	Tweco®	Lincoln®
250153545L2	.035"-.045"/0.9mm-1.2mm	15' (4.6M)	Tweco®	Tweco®	Lincoln®
250153035E	.030"-.035"/0.8mm-0.9mm	15' (4.6M)	Tweco®	Euro	Euro
250153545E	.035"-.045"/0.9mm-1.2mm	15' (4.6M)	Tweco®	Euro	Euro

Pistola MIG disponibles

Pin Connector/Conector



Trigger Connector / Conector de gatillo

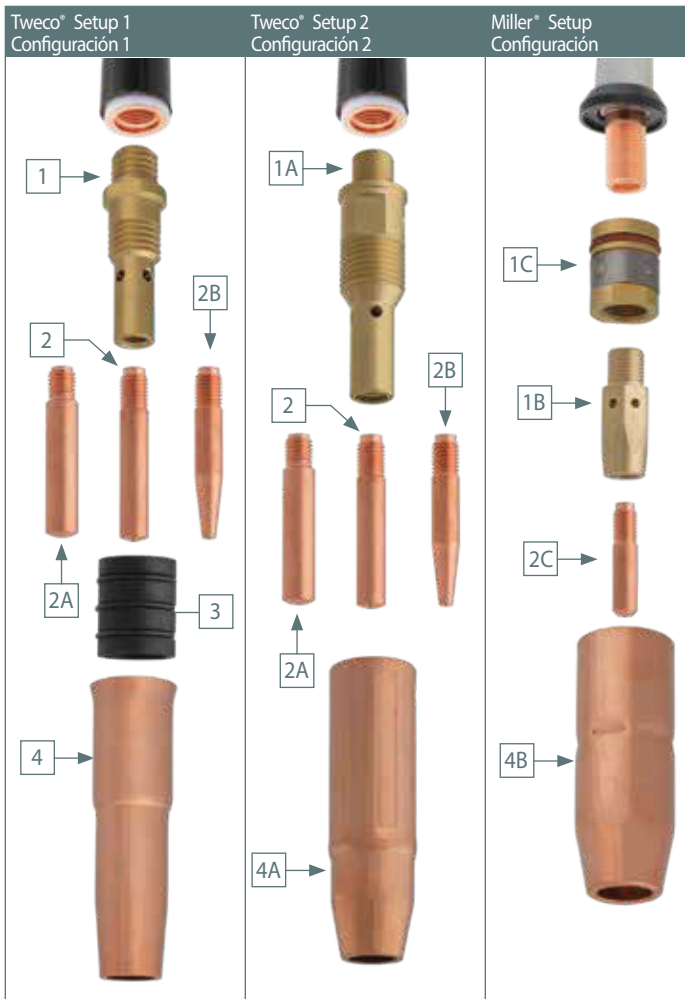

#	Part#	Description
Tweco® Style / Estilo Tweco®		
1	52	Standard Diffuser Difusor normal
1A	52FN	Optional Diffuser Difusor opcional
Miller® Style / Estilo Miller®		
1B	169-728	Diffuser Difusor
1C	169-729	Nozzle Retainer Retenedor de la boquilla

#	Part#	Description	Descripción	Size / Tamaño
Tweco® Style Contact Tip / Puntas de contacto Estilo Tweco®				
2	14-23	Standard	Estándar	.023" (0.6mm)
	14-30	Standard	Estándar	.030" (0.8mm)
	14-35	Standard	Estándar	.035" (0.9mm)
	14-45	Standard	Estándar	.045" (1.2mm)
2A	14H-35	Heavy Duty	Tarea pesada	.035" (0.9mm)
	14H-45	Heavy Duty	Tarea pesada	.045" (1.2mm)
2B	14T-30	Tapered	Ahusadas	.030" (0.8mm)
	14T-35	Tapered	Ahusadas	.035" (0.9mm)
	14T-45	Tapered	Ahusadas	.045" (1.2mm)
Miller® Style Contact Tip / Puntas de contacto Estilo Miller®				
2C	087-299	Standard	Estándar	.023" (0.6mm)
	000-067	Standard	Estándar	.030" (0.8mm)
	000-068	Standard	Estándar	.035" (0.9mm)
	000-069	Standard	Estándar	.045" (1.2mm)

#	Part#	Description	Descripción
Tweco® Style Nozzles / Boquilla Estilo Tweco®			
3	32	Insulator	Aislante
4	22-37-SS	Short Stop 1/8" Recess	Parada corta 1/8" Empotrada
	22-50	Adjustable	Ajustable
	22-50-SS	Short Stop 1/8" Recess	Parada corta 1/8" Empotrada
	22-62	Adjustable	Ajustable
	22-62-SS	Short Stop 1/8" Recess	Parada corta 1/8" Empotrada
4A	23-37	Insulated 1/8" Recess	Aislado, 1/8" Empotrada
	23-50	Insulated 1/8" Recess	Aislado, 1/8" Empotrada
	23-62	Insulated 1/8" Recess	Aislado, 1/8" Empotrada
	23-75	Insulated 1/8" Recess	Aislado, 1/8" Empotrada
	23T-37	Insulated, Tapered	Aislado, ahusadas
	23T-37F	Insulated, Tapered, Flush	Aislado, ahusadas, romo
Miller® Style Nozzles / Boquilla Estilo Miller®			
4B	169-724	Insulated 1/8" Recess	Aislado, 1/8" Empotrada
	200-258	Insulated, Flush	Aislado, romo
	169-725	Insulated 1/8" Recess	Aislado, 1/8" Empotrada
	169-726	Insulated, Flush	Aislado, romo
	169-727	Insulated, Stick-out	Aislado, protuberante de juego





# MIG GUNS

280 Amp Air-Cooled  
Parts Breakdown

# PISTOLA MIG

Pistolas MIG 280A enfriadas por aire  
Desglose de Partes

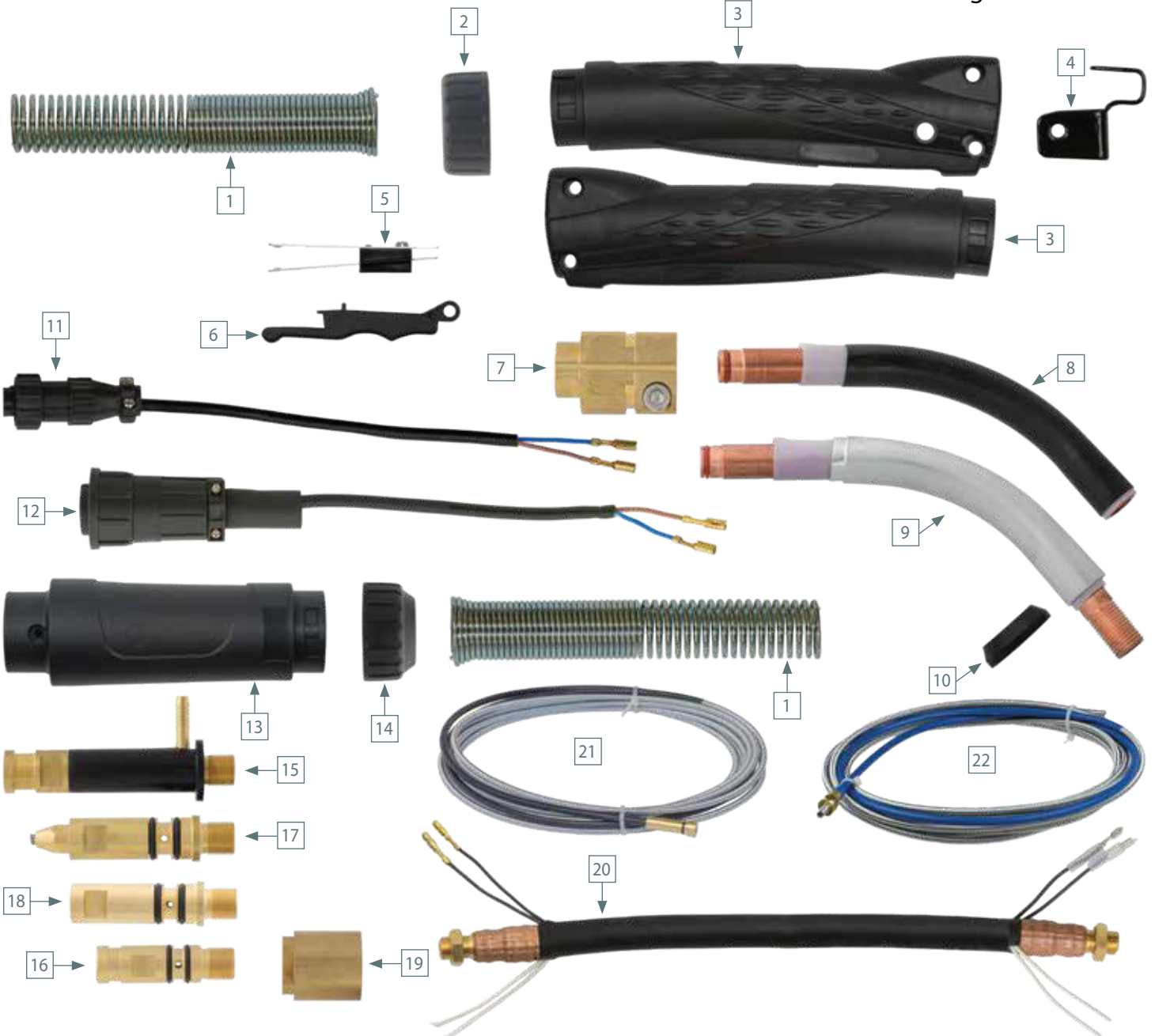

#	Part#	Description		#	Part#	Description	Descripción	Size / Tamaño
1	25SR	Strain Relief	Resorte para alivio tensión	15	25LC	Connector Lincoln	Conector Lincoln	
2	25HR	Handle Locking Ring	Mango el anillo de seguridad	16	25TC	Connector Tweco	Conector Tweco	
3	25HD	Handle 2pcs w/Screws	Manija 2 piezas con tornillos	17	25MC	Connector Miller	Conector Miller	
4	25GH	Gun Hanger	Gancho del interruptor	18	25MCM	Connector Miller	Conector Miller	
5	25TB	Trigger Blade	Hoja de gatillo	19	25CB	Connector Body	Cuerpo conector	
6	25TR	Comfort Grip Trigger	Gatillo de agarre cómodo	20	25PC	Power Cable 15'	Cable de energía 15'	
7	25BK	Tube Block	Bloque de tubo	21	42-23-15	Tweco® Style Liner	Sirga de estilo Tweco®	.023" x 15'
8	25CT	Conductor Tube Tweco	Cuello de estilo Tweco		42-3035-15	Tweco® Style Liner	Sirga de estilo Tweco®	.030"-0.035" x 15'
9	25CTM	Conductor Tube Miller	Cuello de estilo Miller		42-4045-15	Tweco® Style Liner	Sirga de estilo Tweco®	.040"-0.045" x 15'
10	169-730	Insulator Miller	Conector de gatillo Miller		42-3035-25	Tweco® Style Liner	Sirga de estilo Tweco®	.030"-0.035" x 25'
11	25MA	Trigger Connector Miller	Conector de gatillo Miller		42-4045-25	Tweco® Style Liner	Sirga de estilo Tweco®	.040"-0.045" x 25'
12	25LA	Trigger Connector Lincoln	Conector de gatillo Lincoln	22	194-010	Miller® Style Liner	Sirga de estilo Miller®	.023"-0.025" x 15'
13	25CA	Connector Case	Caja del conector		194-011	Miller® Style Liner	Sirga de estilo Miller®	.030"-0.035" x 15'
14	25CR	Connector Locking Ring	Anillo de bloqueo del conector		194-012	Miller® Style Liner	Sirga de estilo Miller®	.040"-0.045" x 15'



**BRIGHTON-BEST**  
**INTERNATIONAL**



# MIG GUNS

400 Amp Air-Cooled  
Available Guns & Setup Options

# PISTOLA MIG

Pistolas MIG 400A enfriadas por aire  
Pistolas & configuraciones disponibles



Pin Connector/Conector



Trigger Connector / Conector de gatillo



Available MIG Guns

Part # Número de la parte	Length Longitud	Pin Connector Conector	Trigger Connector Conector de gatillo
400153545T	.035"-.045"/0.9mm-1.2mm	15' (4.6M)	Tweco®
40015116T	.045"-.062"/1.2mm-1.6mm	15' (4.6M)	Tweco®
400153545M	.035"-.045"/0.9mm-1.2mm	15' (4.6M)	Miller®
40015116M	.045"-.062"/1.2mm-1.6mm	15' (4.6M)	Miller®
400153545L	.035"-.045"/0.9mm-1.2mm	15' (4.6M)	Lincoln®
40015116L	.045"-.062"/1.2mm-1.6mm	15' (4.6M)	Lincoln®
400153545L2	.035"-.045"/0.9mm-1.2mm	15' (4.6M)	Tweco®
40015116L2	.045"-.062"/1.2mm-1.6mm	15' (4.6M)	Tweco®

Pistola MIG disponibles

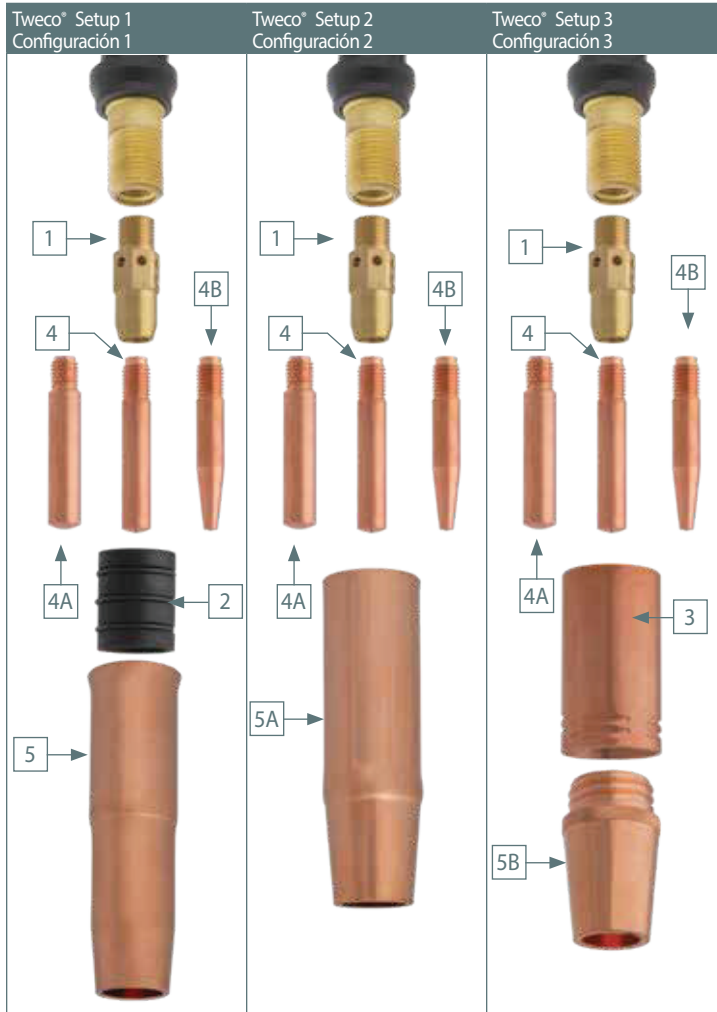

#	Part#	Description	Descripción
1	54A	Diffuser	Difusor
2	34A	Insulator	Aislante
3	34CT	Insulator	Aislante

#	Part#	Description	Descripción	Size / Tamaño
4	14-23	Standard	Estándar	.023" (0.6mm)
	14-30	Standard	Estándar	.030" (0.8mm)
	14-35	Standard	Estándar	.035" (0.9mm)
	14-45	Standard	Estándar	.045" (1.2mm)
	14-52	Standard	Estándar	.052" (1.3mm)
	14-116	Standard	Estándar	1/16" (1.6mm)
14-564	Standard	Estándar	5/64" (2.0mm)	
4A	14H-35	Heavy Duty	Tarea pesada	.035" (0.9mm)
	14H-45	Heavy Duty	Tarea pesada	.045" (1.2mm)
	14H-52	Heavy Duty	Tarea pesada	.052" (1.3mm)
	14H-116	Heavy Duty	Tarea pesada	1/16" (1.6mm)
	14H-564	Heavy Duty	Tarea pesada	5/64" (2.0mm)
4B	14T-30	Tapered	Ahusadas	.030" (0.8mm)
	14T-35	Tapered	Ahusadas	.035" (0.9mm)
	14T-45	Tapered	Ahusadas	.045" (1.2mm)
	14T-52	Tapered	Ahusadas	.052" (1.3mm)
	14T-116	Tapered	Ahusadas	1/16" (1.6mm)

#	Part#	Description	Descripción	
5	24A-50	Adjustable	Ajustable	1/2"
	24A-50-SS	Short Stop 1/8" Recess	Parada corta 1/8" Empotrada	1/2"
	24A-62	Adjustable	Ajustable	5/8"
	24A-62-SS	Short Stop 1/8" Recess	Parada corta 1/8" Empotrada	5/8"
	24A-75	Adjustable	Ajustable	3/4"
	24A-75-SS	Short Stop 1/8" Recess	Parada corta 1/8" Empotrada	3/4"
5A	23-37	Insulated 1/8" Recess	Aislado, 1/8" Empotrada	3/8"
	23-50	Insulated 1/8" Recess	Aislado, 1/8" Empotrada	1/2"
	23-62	Insulated 1/8" Recess	Aislado, 1/8" Empotrada	5/8"
	23-75	Insulated 1/8" Recess	Aislado, 1/8" Empotrada	3/4"
	23T-37	Insulated, Tapered	Aislado, ahusadas	3/8"
	23T-37F	Insulated, Tapered, Flush	Aislado, ahusadas, romo	3/8"
5B	24CT-50S	C. Thread 1/8" Recess	Hilo grueso 1/8" Empotrada	1/2"
	24CT-62S	C. Thread 1/8" Recess	Hilo grueso 1/8" Empotrada	5/8"
	24CT-75S	C. Thread 1/8" Recess	Hilo grueso 1/8" Empotrada	3/4"



# MIG GUNS

400 Amp Air-Cooled  
Parts Breakdown

# PISTOLA MIG

Pistolas MIG 400A enfriadas por aire  
Desglose de Partes

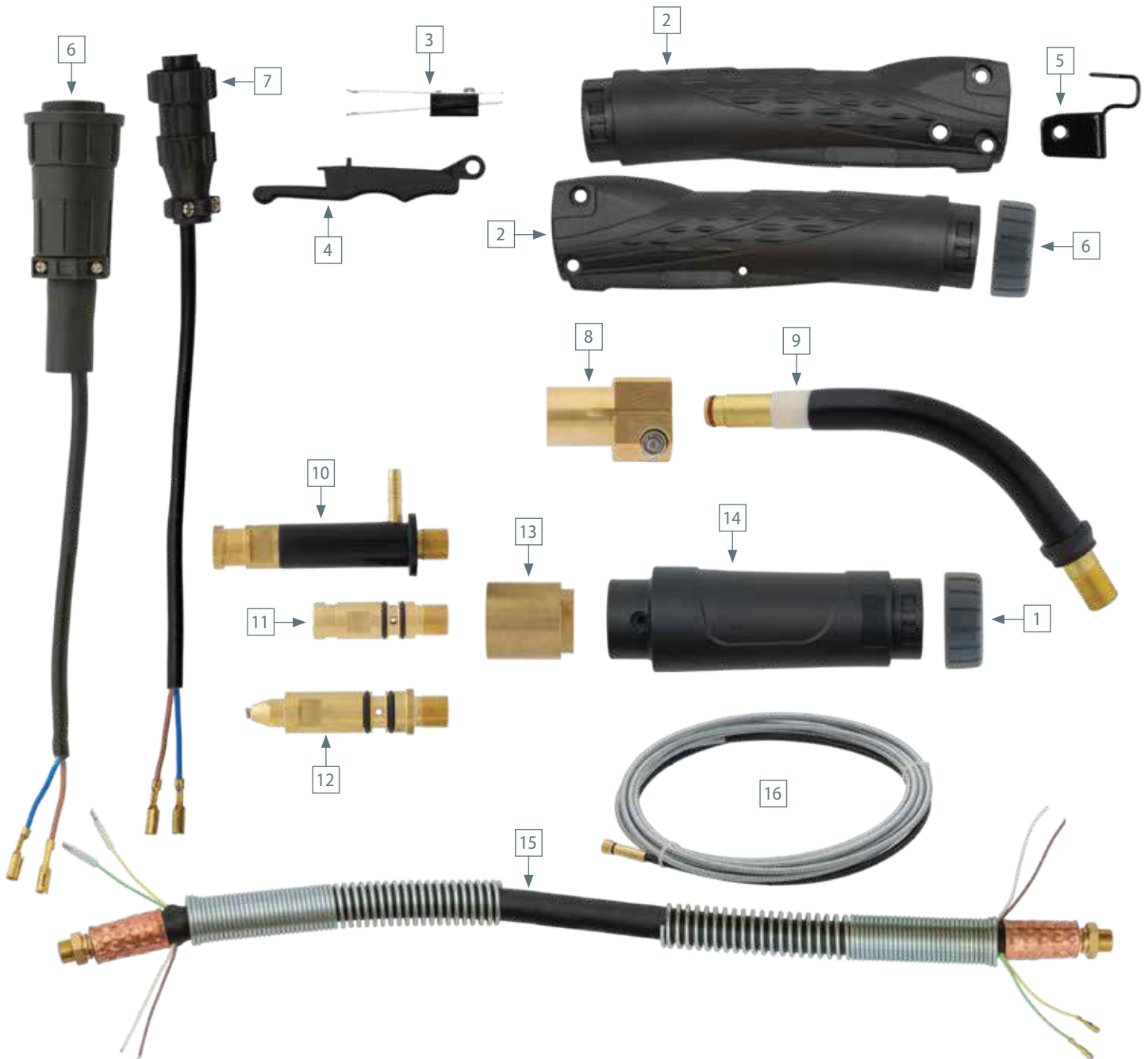

#	Part#	Description	Descripción	#	Part#	Description	Descripción	Size / Tamaño
1	40HR	Locking Ring	Anillo de bloqueo	12	25MC	Connector (Miller)	Conector (Miller)	
2	40HD	Handle 2pcs w/Screws	Mango 2 piezas con tornillos	13	40CB	Connector Body	Cuerpo conector	
3	25TB	Trigger Blade	Hoja de gatillo	14	25CA	Connector Case	Caja del conector	
4	25TR	Comfort Grip Trigger	Gatillo de agarre cómodo	15	40PC	Power Cable	Cable de energía	15'
5	25GH	Gun Hanger	Gancho del interruptor	16	44-3545-15	Liner	Sirga	.035"-.045" x 15'
6	25LA	Trigger Connector (Lincoln)	Conector de gatillo (Lincoln)		44-116-15	Liner	Sirga	.052"-1/16" x 15'
7	25MA	Trigger Connector (Miller)	Conector de gatillo (Miller)		44-564-15	Liner	Sirga	5/64" x 15'
8	40BK	Tube Block	Bloque de tubo		44-3545-25	Liner	Sirga	.035"-.045" x 25'
9	40CT	Conductor Tube	Cuello		44-116-25	Liner	Sirga	.052"-1/16" x 25'
10	25LC	Connector (Lincoln)	Conector (Lincoln)		44-564-25	Liner	Sirga	5/64" x 25'
11	25TC	Connector (Twecd)	Conector (Twecd)					



**BRIGHTON-BEST  
INTERNATIONAL**

# MIG GUNS

400 Amp Air-Cooled  
Available Guns & Setup Options

# PISTOLA MIG

Pistolas MIG 400A enfriadas por aire  
Pistolas & configuraciones disponibles



Pin Connector/Conector



Available MIG Guns

Part # Número de la parte	Wire Size Tamaño del cable	Length Longitud	Pin Connector Conector	Trigger Connector Conector de gatillo
4153545T	.035"-.045"/0.9mm-1.2mm	15' (4.6M)	Tweco®	Miller®
415116T	.045"-.062"/1.2mm-1.6mm	15' (4.6M)	Tweco®	Miller®
4153545M	.035"-.045"/0.9mm-1.2mm	15' (4.6M)	Miller®	Miller®
415116M	.045"-.062"/1.2mm-1.6mm	15' (4.6M)	Miller®	Miller®
4153545L	.035"-.045"/0.9mm-1.2mm	15' (4.6M)	Lincoln®	Lincoln®
415116L	.045"-.062"/1.2mm-1.6mm	15' (4.6M)	Lincoln®	Lincoln®

Pistola MIG disponibles

Trigger Connector / Conector de gatillo

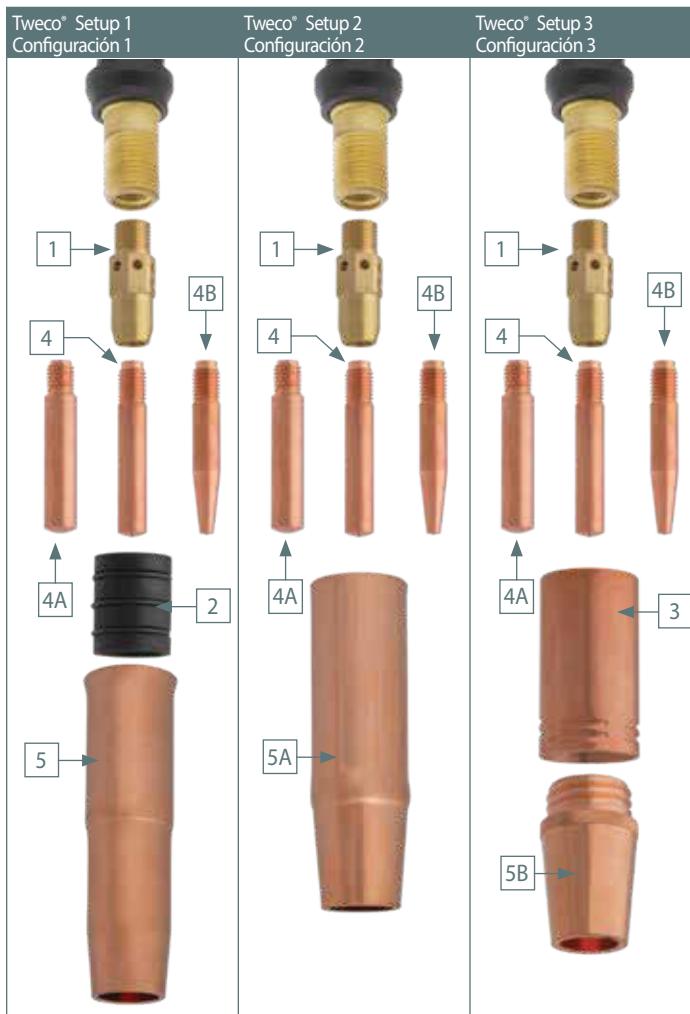

#	Part#	Description	Descripción
1	54A	Diffuser	Difusor
2	34A	Insulator	Aislante
3	34CT	Insulator	Aislante

#	Part#	Description	Descripción	Size / Tamaño
4	14-23	Standard	Estándar	.023" (0.6mm)
	14-30	Standard	Estándar	.030" (0.8mm)
	14-35	Standard	Estándar	.035" (0.9mm)
	14-45	Standard	Estándar	.045" (1.2mm)
	14-52	Standard	Estándar	.052" (1.3mm)
	14-116	Standard	Estándar	1/16" (1.6mm)
	14-564	Standard	Estándar	5/64" (2.0mm)
4A	14H-35	Heavy Duty	Tarea pesada	.035" (0.9mm)
	14H-45	Heavy Duty	Tarea pesada	.045" (1.2mm)
	14H-52	Heavy Duty	Tarea pesada	.052" (1.3mm)
	14H-116	Heavy Duty	Tarea pesada	1/16" (1.6mm)
	14H-564	Heavy Duty	Tarea pesada	5/64" (2.0mm)
4B	14T-30	Tapered	Ahusadas	.030" (0.8mm)
	14T-35	Tapered	Ahusadas	.035" (0.9mm)
	14T-45	Tapered	Ahusadas	.045" (1.2mm)
	14T-52	Tapered	Ahusadas	.052" (1.3mm)
	14T-116	Tapered	Ahusadas	1/16" (1.6mm)

#	Part#	Description	Descripción	
5	24A-50	Adjustable	Ajustable	1/2"
	24A-50-SS	Short Stop 1/8" Recess	Parada corta 1/8" Empotrada	1/2"
	24A-62	Adjustable	Ajustable	5/8"
	24A-62-SS	Short Stop 1/8" Recess	Parada corta 1/8" Empotrada	5/8"
	24A-75	Adjustable	Ajustable	3/4"
	24A-75-SS	Short Stop 1/8" Recess	Parada corta 1/8" Empotrada	3/4"
5A	23-37	Insulated 1/8" Recess	Aislado, 1/8" Empotrada	3/8"
	23-50	Insulated 1/8" Recess	Aislado, 1/8" Empotrada	1/2"
	23-62	Insulated 1/8" Recess	Aislado, 1/8" Empotrada	5/8"
	23-75	Insulated 1/8" Recess	Aislado, 1/8" Empotrada	3/4"
	23T-37	Insulated, Tapered	Aislado, ahusadas	3/8"
	23T-37F	Insulated, Tapered, Flush	Aislado, ahusadas, romo	3/8"
	5B	24CT-50S	C. Thread 1/8" Recess	Hilo grueso 1/8" Empotrada
24CT-62S		C. Thread 1/8" Recess	Hilo grueso 1/8" Empotrada	5/8"
24CT-75S		C. Thread 1/8" Recess	Hilo grueso 1/8" Empotrada	3/4"



# MIG GUNS

400 Amp Air-Cooled  
Parts Breakdown

# PISTOLA MIG

Pistolas MIG 400A enfriadas por aire  
Desglose de Partes

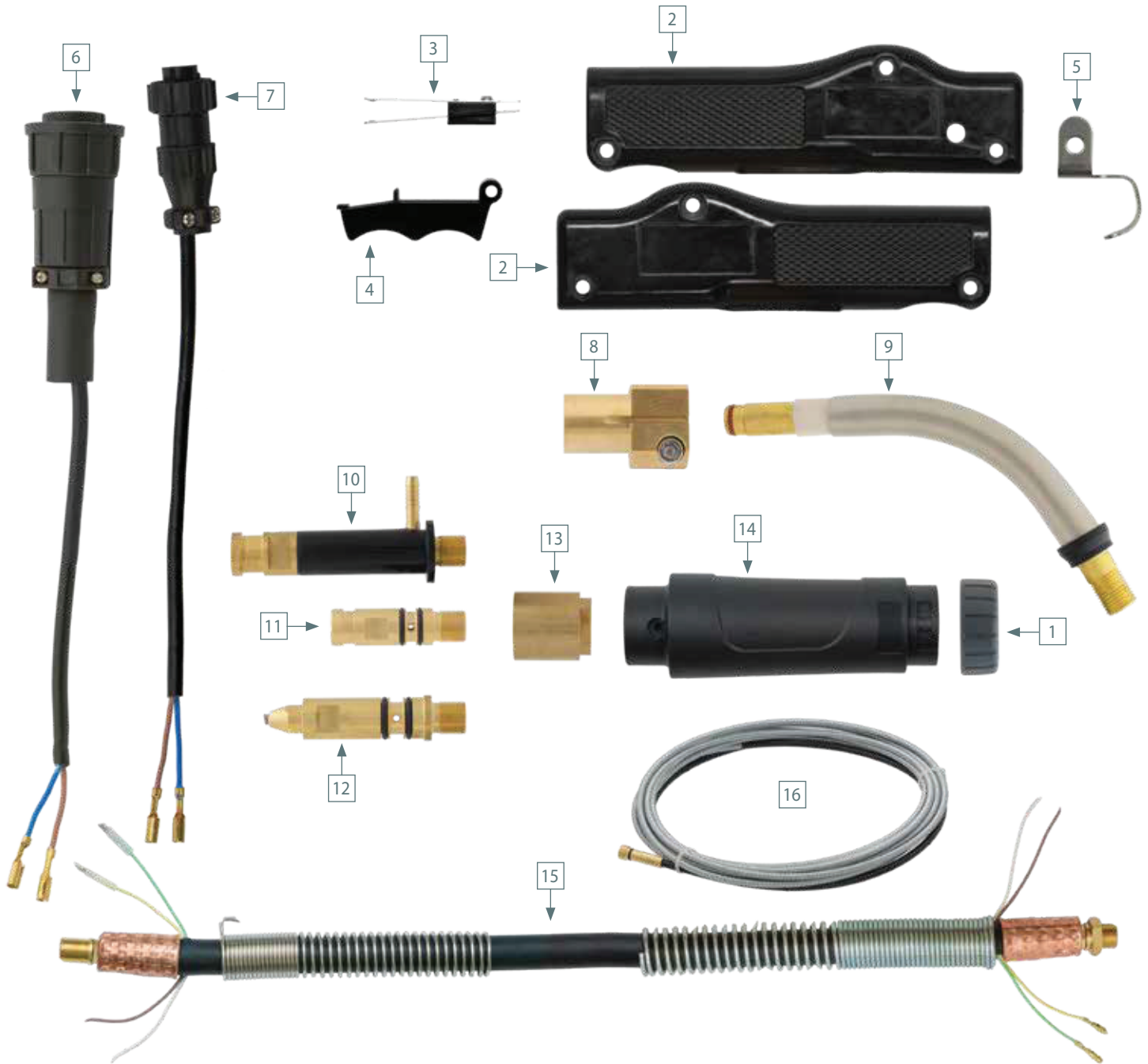

#	Part#	Description	Descripción	#	Part#	Description	Descripción	Size / Tamaño
1	40HR	Locking Ring	Anillo de bloqueo	12	25MC	Connector (Miller)	Conector (Miller)	
2	415HD	Handle 2pcs w/Screws	Mango 2 piezas con tornillos	13	40CB	Connector Body	Cuerpo conector	
3	25TB	Trigger Blade	Hoja de gatillo	14	25CA	Connector Case	Caja del conector	
4	415TR	Trigger	Gatillo	15	415PC	Power Cable	Cable de energía	15'
5	415GH	Gun Hanger	Gancho del interruptor	16	44-3545-15	Liner	Sirga	.035"-.045" x 15'
6	25LA	Trigger Connector (Lincoln)	Conector de gatillo (Lincoln)		44-116-15	Liner	Sirga	.052"-1/16" x 15'
7	25MA	Trigger Connector (Miller)	Conector de gatillo (Miller)		44-564-15	Liner	Sirga	5/64" x 15'
8	40BK	Tube Block	Bloque de tubo		44-3545-25	Liner	Sirga	.035"-.045" x 25'
9	415CT	Conductor Tube	Cuello		44-116-25	Liner	Sirga	.052"-1/16" x 25'
10	25LC	Connector (Lincoln)	Conector (Lincoln)		44-564-25	Liner	Sirga	5/64" x 25'
11	25TC	Connector (Tweco)	Conector (Tweco)					



**BRIGHTON-BEST  
INTERNATIONAL**





#	Part#	Description	Descripción	Gun / Pistola
Gas Diffuser / Difusor de gas				
1	35-50	Diffuser	Difusor	135, Mini®
2	51	Diffuser	Difusor	Tweco® #1
3	51-23	Diffuser .023" (0.6mm)	Difusor .023" (0.6mm)	Tweco® #1
	52	Diffuser	Difusor	250, Tweco® #2
4	52FN	Diffuser	Difusor	250, Tweco® #2
5	54A	Diffuser (Brass)	Difusor (latón)	400, Tweco® #4
	54P	Diffuser (Copper)	Difusor (cobre)	400, Tweco® #4
6	HD54-16	Diffuser	Difusor	400, Tweco® #4
7	55	Diffuser	Difusor	400, Tweco® #4
	55SW	Diffuser	Difusor	400, Tweco® #4
	55H	Diffuser	Difusor	400, Tweco® #4

#	Part#	Description	Descripción	Gun / Pistola
Insulators / Aislantes				
8	32	Insulator	Aislante	250, Tweco® #2
	34A	Insulator	Aislante	400, Tweco® #4
9	34CT	Coarse Thread	Rosca gruesa	250, 400, Tweco® #2 & #4
	35CT	Coarse Thread	Rosca gruesa	400, Tweco® #4 & #5
10	34FN	Fine Thread	Rosca fina	250, 400, Tweco® #2 & #4

#	Part#	Description	Descripción	Size / Tamaño	Gun / Pistola
Contact Tips / Puntas de contacto					
11	11-23	Standard	Estándar	.023" (0.6mm)	135/Mini® #1
	11-30	Standard	Estándar	.030" (0.8mm)	
	11-35	Standard	Estándar	.035" (0.9mm)	
	11-45	Standard	Estándar	.045" (1.2mm)	
12	11T-23	Tapered	Ahusadas	.023" (0.6mm)	
	11T-30	Tapered	Ahusadas	.030" (0.8mm)	
	11T-35	Tapered	Ahusadas	.035" (0.9mm)	
13	14-23	Standard	Estándar	.023" (0.6mm)	250, 400, Tweco® #2 & #4
	14-30	Standard	Estándar	.030" (0.8mm)	
	14-35	Standard	Estándar	.035" (0.9mm)	
	14-45	Standard	Estándar	.045" (1.2mm)	
	14-52	Standard	Estándar	.052" (1.3mm)	
	14-116	Standard	Estándar	1/16" (1.6mm)	
	14-564	Standard	Estándar	5/64" (2.0mm)	
14	14H-35	Heavy Duty	Tarea pesada	.035" (0.9mm)	
	14H-45	Heavy Duty	Tarea pesada	.045" (1.2mm)	
	14H-52	Heavy Duty	Tarea pesada	.052" (1.3mm)	
	14H-116	Heavy Duty	Tarea pesada	1/16" (1.6mm)	
	14H-564	Heavy Duty	Tarea pesada	5/64" (2.0mm)	
15	14T-30	Tapered	Ahusadas	.030" (0.8mm)	250, 400, Tweco® #2 & #4
	14T-35	Tapered	Ahusadas	.035" (0.9mm)	
	14T-45	Tapered	Ahusadas	.045" (1.2mm)	
	14T-52	Tapered	Ahusadas	.052" (1.3mm)	
	14T-116	Tapered	Ahusadas	1/16" (1.6mm)	
16	15H-35	Heavy Duty	Tarea pesada	.035" (0.9mm)	
	15H-45	Heavy Duty	Tarea pesada	.045" (1.2mm)	
	15H-52	Heavy Duty	Tarea pesada	.052" (1.3mm)	
	15H-116	Heavy Duty	Tarea pesada	1/16" (1.6mm)	
	15H-564	Heavy Duty	Tarea pesada	5/64" (2.0mm)	
	15H-332	Heavy Duty	Tarea pesada	3/32" (2.4mm)	
17	15HFC-45	Heavy Duty	Tarea pesada	.045" (1.2mm)	250, 400, Tweco® #2 & #4
	15HFC-116	Heavy Duty	Tarea pesada	1/16" (1.6mm)	
	15HFC-564	Heavy Duty	Tarea pesada	5/64" (2.0mm)	
	15HFC-332	Heavy Duty	Tarea pesada	3/32" (2.4mm)	
18	16S-35	Heavy Duty	Tarea pesada	.035" (0.9mm)	
	16S-45	Heavy Duty	Tarea pesada	.045" (1.2mm)	
	16S-52	Heavy Duty	Tarea pesada	.052" (1.3mm)	
	16S-116	Heavy Duty	Tarea pesada	1/16" (1.6mm)	
	16S-564	Heavy Duty	Tarea pesada	5/64" (2.0mm)	
	16S-332	Heavy Duty	Tarea pesada	3/32" (2.4mm)	
	16S-764	Heavy Duty	Tarea pesada	7/64" (2.8mm)	
19	16ST-35	Tapered	Ahusadas	.035" (0.9mm)	
	16ST-45	Tapered	Ahusadas	.045" (1.2mm)	



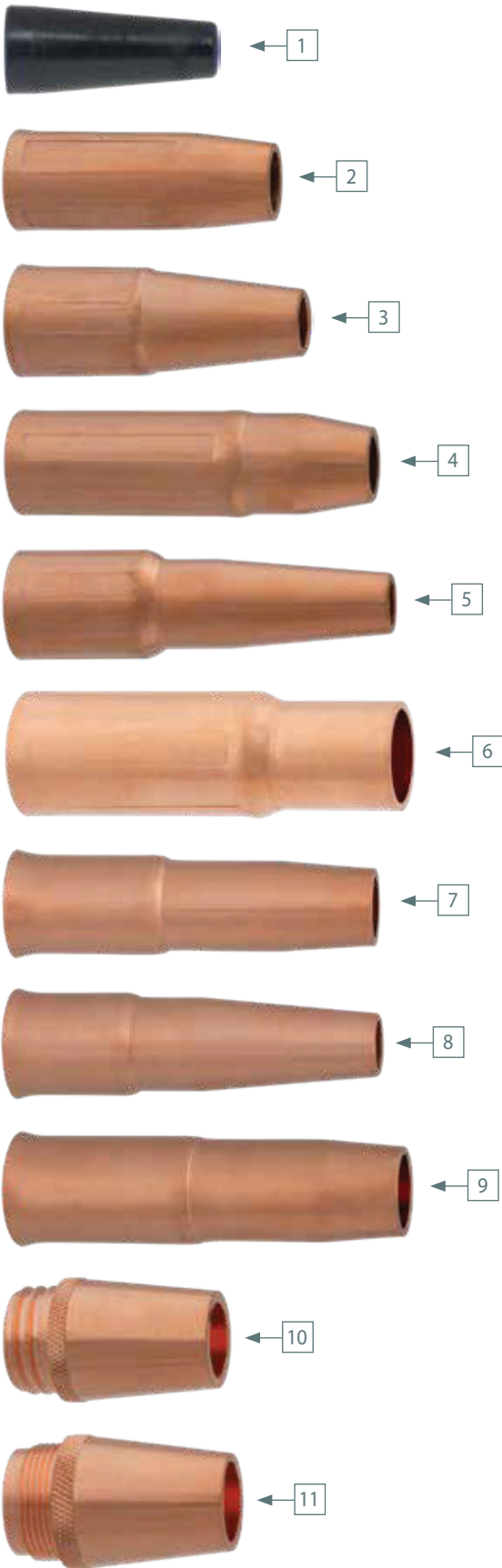

#	Part#	Description	Descripción	Size / Tamaño	Gun / Pistola
<b>Insulated Nozzles</b>					
1	KP1939-1	Gasless Nozzle	Boquilla sin gas		135/Mini® #1
2	21-37	1/8" Recess	1/8" Empotrada		
	21-50	1/8" Recess	1/8" Empotrada		
	21-50F	Flush	Romo		
	21-62	1/8" Recess	1/8" Empotrada		
3	21T-37	Tapered	Ahusadas		250, 400, Tweco® #2 & #4
4	23-37	1/8" Recess	1/8" Empotrada		
	23-50	1/8" Recess	1/8" Empotrada		
	23-62	1/8" Recess	1/8" Empotrada		
	23-75	1/8" Recess	1/8" Empotrada		
5	23T-37	Tapered	Ahusadas		
	23T-37F	Flush, Tapered	Romo, Ahusadas		
6	HD24L-62	H.D. 1/8" Recess	H.D. 1/8" Empotrada		
	HD24L-75	H.D. 1/8" Recess	H.D. 1/8" Empotrada		
<b>Slip-on Nozzles / Boquilla encajable</b>					
7	22-37-SS	1/8" Recess	1/8" Empotrada	3/8"	250, Tweco® #2
	22-50	Adjustable	Ajustable	1/2"	
	22-50-SS	1/8" Recess	1/8" Empotrada	1/2"	
	22-62	Adjustable	Ajustable	5/8"	
	22-62-SS	1/8" Recess	1/8" Empotrada	5/8"	
8	22T-37-SS	Tapered 1/8" Recess	Ahusadas 1/8" Empotrada		400, Tweco® #4
9	24A-50	Adjustable	Ajustable	1/2"	
	24A-50-SS	1/8" Recess	1/8" Empotrada	1/2"	
	24A-62	Adjustable	Ajustable	5/8"	
	24A-62-SS	1/8" Recess	1/8" Empotrada	5/8"	
	24A-75	Adjustable	Ajustable	3/4"	
	24A-75-SS	1/8" Recess	1/8" Empotrada	3/4"	
<b>Coarse Thread Nozzles / Boquilla de rosca gruesa</b>					
10	24CT-50S	1/8" Recess	1/8" Empotrada	1/2"	250, 400, Tweco® #2 & #4
	24CT-62S	1/8" Recess	1/8" Empotrada	5/8"	
	24CT-75S	1/8" Recess	1/8" Empotrada	3/4"	
<b>Fine Thread Nozzles / Boquilla de rosca fina</b>					
11	24FN-50S	1/8" Recess	1/8" Empotrada	1/2"	250, 400, Tweco® #2 & #4
	24FN-62S	1/8" Recess	1/8" Empotrada	5/8"	
	24FN-75S	1/8" Recess	1/8" Empotrada	3/4"	



#	Part#	Wire Size / Tamaño del cable	Length / Longitud	Gun / Pistola
<b>Liners / Sirga</b>				
12	35-40-15	.030"-035"	15'	135, Mini® #1
	45-40-15	.035"-045"	15'	
13	42-23-15	.023"	15'	250, Tweco® #2
	42-3035-15	.030"-035"	15'	
	42-4045-15	.040"-045"	15'	
	42-3035-25	.030"-035"	25'	
	42-4045-25	.040"-045"	25'	
	44-3545-15	.035"-045"	15'	400, Tweco® #4
	44-116-15	1/16"	15'	
	44-564-15	5/64"	15'	
	44-564-25	5/64"	25'	
	44-3545-25	.035"-045"	25'	
	44-116-25	1/16"	25'	

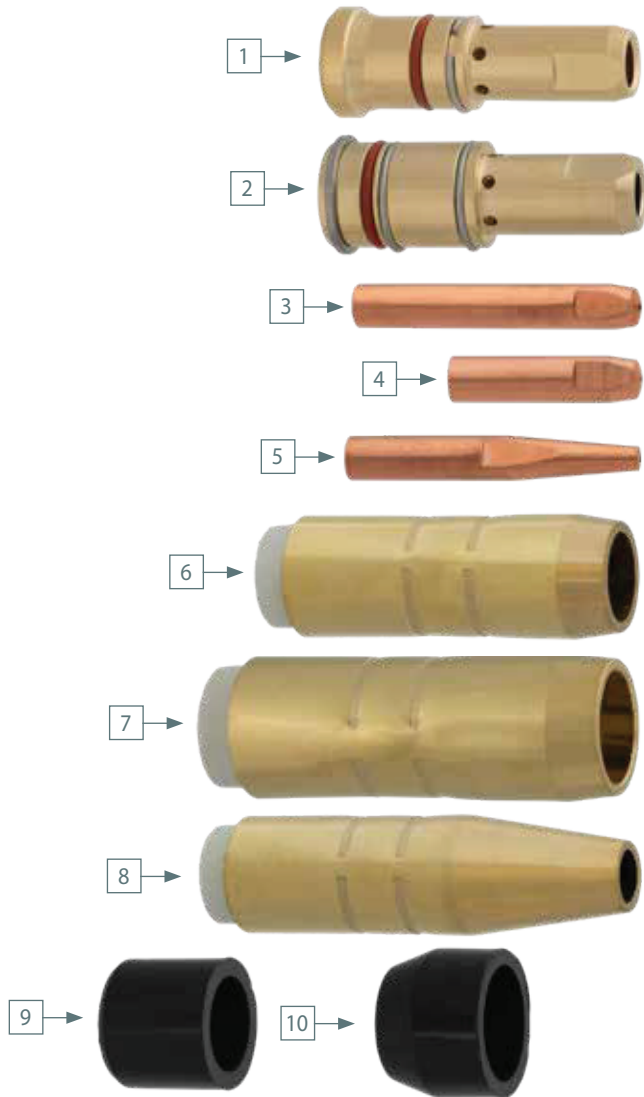

#	Part#	Description	Descripción
Gas Diffuser / Difusor de gas			
1	4235	For 1500 series tips	Para serie de puntas 1500
	4335	For 7400 & 4200 series tips	Para serie de puntas 7400 & 4200
2	4435	For 7400 series tips	Para serie de puntas 7400
	4635	For 1500 series tips	Para serie de puntas 1500

#	Part#	Size / Tamaño	Use diffuser / Usar con difusor
Contact Tips / Puntas de contacto			
3	1588	.030" (0.8mm)	4235 & 4635
	1589	.035" (0.9mm)	
	1590	.045" (1.2mm)	
	1591	1/16" (1.6mm)	
	1592	5/64" (2.0mm)	
	1593	3/32" (2.4mm)	
4	7488	.030" (0.8mm)	4335 & 4435
	7489	.035" (0.9mm)	
	7490	.045" (1.2mm)	
	7491	1/16" (1.6mm)	
	7492	5/64" (2.0mm)	
	7493	3/32" (2.4mm)	
5	4281	.035" (0.9mm)	4335
	4282	.045" (1.2mm)	

#	Part#	Material	Size / Tamaño	UYse diffuser / Usar con difusor
Nozzles / Boquillas				
6	4391	Brass/Latón	5/8"	4235 & 4335
	4392	Brass/Latón	1/2"	
	4393	Copper/Cobre	5/8"	
	4394	Copper/Cobre	1/2"	
7	4491	Brass/Latón	3/4"	4435 & 4635
	4492	Brass/Latón	9/16"	
	4591	Copper/Cobre	3/4"	
	4592	Copper/Cobre	9/16"	
8	4295	Brass/Latón	3/8"	4335

#	Part#	Description	Descripción	Guns / Pistolas
Insulators / Aislantes				
9	4323R	Insulator Cap	Tapa aislante	200-300A
10	4423R	Insulator Cap	Tapa aislante	350-500A



#	Part#	Wire Size / Tamaño del cable	Length / Longitud
Liners / Sirga			
11	43015	.023"-0.030"	15'
	43115	.035"-0.045"	15'
	43215	.045"-1/16"	15'
	44115	.035"-0.045"	15'
	44215	.045"-0.062"	15'
	44225	.045"-0.062"	25'
	45415	3/32"	15'

### Bernard®/Tregaskiss® Style Universal Liners

### Sirgas universales estilo Bernard®/Tregaskiss®



#	Part#	Wire Size / Tamaño del cable	Length / Longitud	Color	Replace / Reemplazar Bernard®	Replace / Reemplazar Tregaskiss®
Liners / Sirga						
12	L1A-15	.023" - .030"	15'	Yellow / Amarilla	43015	415-23-15
13	L3A-15	.035" - .045"	15'	White / Blanca	44115	415-35-15
	L3A-25	.035" - .045"	25'	White / Blanca	44125	415-35-25
14	L3B-15	.035" - .045"	15'	Brown / Marrón	43115	—
	L3B-25	.035" - .045"	25'	Brown / Marrón	43125	—
15	L4A-15	.045" - 1/16"	15'	Red / Roja	44215	415-116-15
	L4A-25	.045" - 1/16"	25'	Red / Roja	44225	415-116-25
16	L5A-15	1/16" - 5/64"	15'	Orange / Naranja	44315	415-564-15
	L5A-25	1/16" - 5/64"	25'	Orange / Naranja	44325	415-564-25
17	L6A-15	5/64"	15'	Blue / Azul	45415	415-332-15
	L6A-25	5/64"	25'	Blue / Azul	45425	415-332-25
18	L7A-15	3/32"	15'	Gray / Gris	45615	—
	L7A-25	3/32"	25'	Gray / Gris	45625	—

# MIG CONSUMABLES

Bernard® Centerfire™ Alternative

# CONSUMIBLES MIG

Alternativa Bernard® Centerfire™

Bernard® Centerfire™ consumables are very expensive! However, \$\$ can be saved by simply replacing these patented parts with Bernard® traditional style nozzles, contact tips and diffusers.

Consumibles Bernard® Centerfire™ son muy caros! Sin embargo, \$\$ puede ser ahorrado simplemente reemplazando estas partes patentadas con boquillas, puntas y difusores de contacto estilo Bernard.

Item	Centerfire™	Traditional Long Tip	Traditional Short Tip
Diffuser	D-1	4635	4435
	T-030	1588	7488
Contact Tip	T-035	1589	7489
	T-045	1590	7490
	T-052	1598	7498
	T-062	1591	7491
	T-078	1592	7492
	T-094	1593	7493
Nozzles	N-5800C	4592	
	N-5818C		
	N-5814C		
	N-5800B		
	N-5818B	4492	
	N-5814B		
	N-3400C		
	N-3418C		
N-3414C			
N-3418B			
N-3414B	4491		

Item	Centerfire™	Traditional Long Tip	Traditional Short Tip
Diffuser	DS-1	4235	4335
	T-030	1588	7488
Contact Tip	T-035	1589	7489
	T-045	1590	7490
	T-052	1598	7498
	T-062	1591	7491
	T-078	1592	7492
	T-094	1593	7493
Nozzles	NS-1218C	4394	
	NS-1200B	4392	
	NS-1218B		
	NS-5800C	4393	
	NS-5818C		
	NS-5800B	4391	
NS-5818B			
NS-5814B			

Item	Centerfire™	Traditional
Diffuser	DS-1	4335
Contact Tips	TT-035	4281
	TT-045	4282
Nozzles	NST-3800B	4295
	NST-3818B	

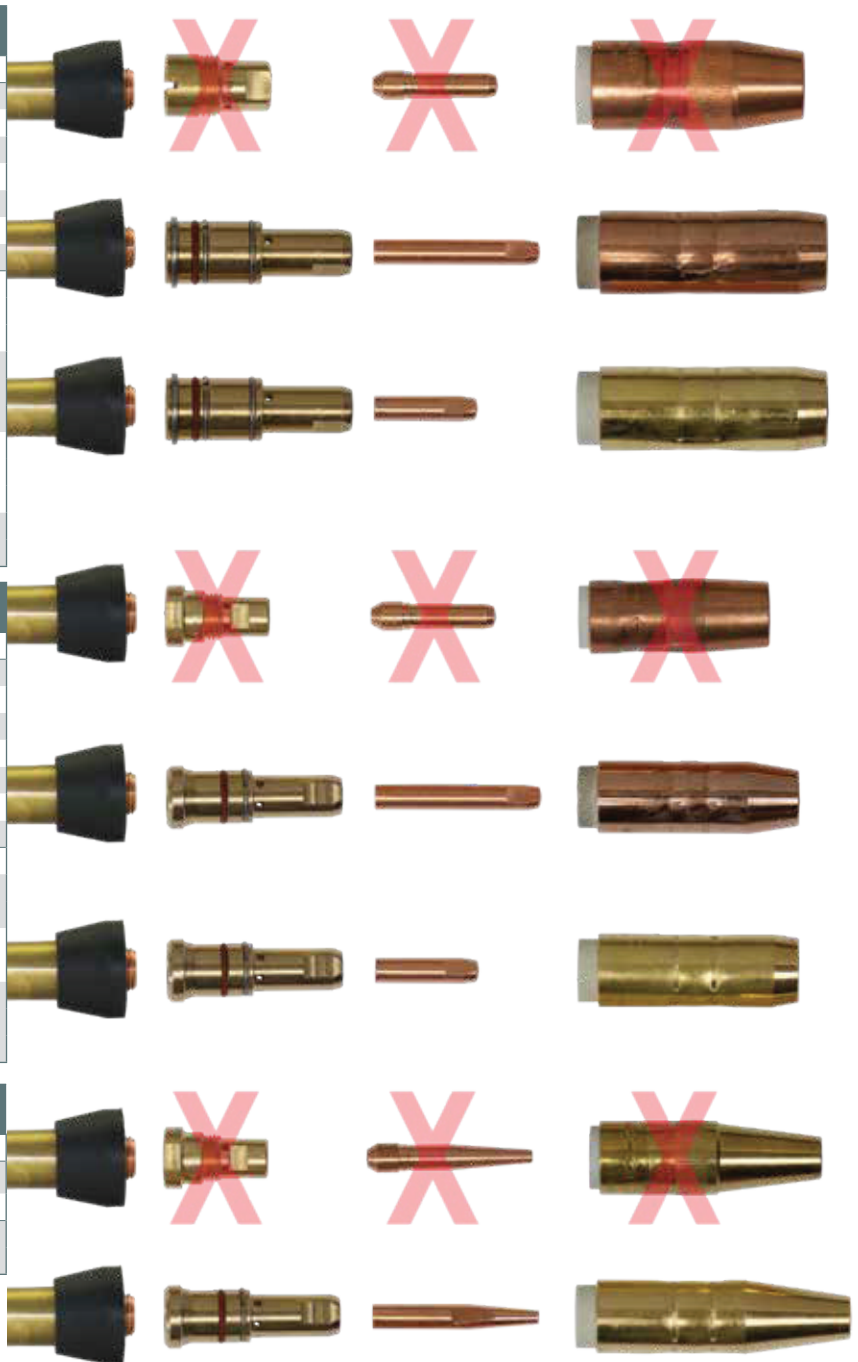

**BRIGHTON-BEST INTERNATIONAL**



#	Part#	Description	Descripción
Gas Diffuser / Difusor de gas			
1	402-3	Nozzle Retainer	Retenedor de boquilla
2	404	For Standard Tips	Para punta estándar
	404-1	For Heavy Duty Tips	Para punta de uso pesado
3	404-3	For Heavy Duty Tips	Para punta de uso pesado
	404-13	For Heavy Duty Tips	Para punta de uso pesado

#	Part#	Description	Descripción	Size / Tamaño
Contact Tips / Puntas de contacto				
4	403-30	Standard	Estándar	.030" (0.8mm)
	403-35	Standard	Estándar	.035" (0.9mm)
	403-45	Standard	Estándar	.045" (1.2mm)
	403-52	Standard	Estándar	.052" (1.3mm)
	403-116	Standard	Estándar	1/16" (1.6mm)
5	403-1-30	Heavy Duty	Tarea pesada	.030" (0.8mm)
	403-1-35	Heavy Duty	Tarea pesada	.035" (0.9mm)
	403-1-45	Heavy Duty	Tarea pesada	.045" (1.2mm)
	403-1-52	Heavy Duty	Tarea pesada	.052" (1.3mm)
	403-1-16	Heavy Duty	Tarea pesada	1/16" (1.6mm)
	403-1-564	Heavy Duty	Tarea pesada	5/64" (2.0mm)
6	403-2-35	Tapered	Ahusadas	.035" (0.9mm)
	403-2-45	Tapered	Ahusadas	.045" (1.2mm)
7	403-3-30	Tapered H.D.	Ahusadas uso pesado	.030" (0.8mm)
	403-3-35	Tapered H.D.	Ahusadas uso pesado	.035" (0.9mm)
	403-3-45	Tapered H.D.	Ahusadas uso pesado	.045" (1.2mm)
	403-3-52	Tapered H.D.	Ahusadas uso pesado	.052" (1.3mm)

#	Part#	Description	Descripción	Size / Tamaño
Nozzles / Boquilla				
8	401-4-38	Flush Copper	Romo	3/8"
	401-4-50	1/8" Recess Copper	1/8" Empotrada Cobre	1/2"
	401-4-62	1/8" Recess Copper	1/8" Empotrada Cobre	5/8"
	401-5-62	H.D. 1/4" Recess Copper	Uso pesado 1/4" Empotrada Cobre	5/8"
	401-5-75	H.D. 1/4" Recess Copper	Uso pesado 1/4" Empotrada Cobre	3/4"
	401-6-62	H.D. 1/8" Recess Copper	Uso pesado 1/8" Empotrada Cobre	5/8"
	401-6-75	H.D. 1/8" Recess Copper	Uso pesado 1/8" Empotrada Cobre	3/4"
	401-81-62	H.D. 1/8" Recess Copper	Uso pesado 1/8" Empotrada Cobre	5/8"
9	401-7-62	H.D. 1/8" Recess Brass	Uso pesado 1/8" empotrada latón	5/8"
	401-71-62	H.D. 1/8" Recess Brass	Uso pesado 1/8" empotrada latón	5/8"
10	401-48-50	1/8" Stick-out Brass	1/8" protuberante latón	1/2"
11	401-48-62	H.D. Flush Copper	Uso pesado Romo cobre	5/8"



#	Part#	Wire Size Tamaño del cable	Length Longitud
Liners / Sirga			
11	415-35-15	.035"-045"	15'
	415-35-25	.035"-045"	25'
	415-116-2	.045"-1/16" (nylon)	15'
	415-116-6	.045"-1/16"	6'
	415-116-15	.045"-1/16"	15'
	415-116-25	.045"-1/16"	25'
	415-332-15	3/32"	15'

Bernard®/Tregaskiss® Style Universal Liners See Page 14

Sirgas universales estilo Bernard®/ Tregaskiss® ver página 14



#	Part#	Description	Descripción
Insulators / Aislantes			
9	402-7	Standard Duty	Uso estándar
10	402-5	Heavy Duty	Tarea pesada
11	402-11	Heavy Duty	Tarea Pesada



*Tregaskiss® Tough Lock™ consumables are very expensive! However, you can save money by simply replacing these patented parts with Tregaskiss® traditional style contact tips and diffusers.*

*Consumibles Tough Lock™ Tregaskiss® son muy caros! Sin embargo, \$ \$ puede ser ahorrado reemplazandolas con estas piezas Tregaskiss® estilo tradicional incluidas puntas de contacto y difusores.*

Item	Tough Lock™	Traditional
Diffuser Retainer	404-14, 404-18	404
		402-3
Contact Tip	403-14-30	403-30
	403-14-35	403-35
	403-14-45	403-45
	403-14-52	403-52
	403-14-116	403-116
	403-12-35	403-2-35
	403-12-45	403-2-45
Nozzles	Remain the same	

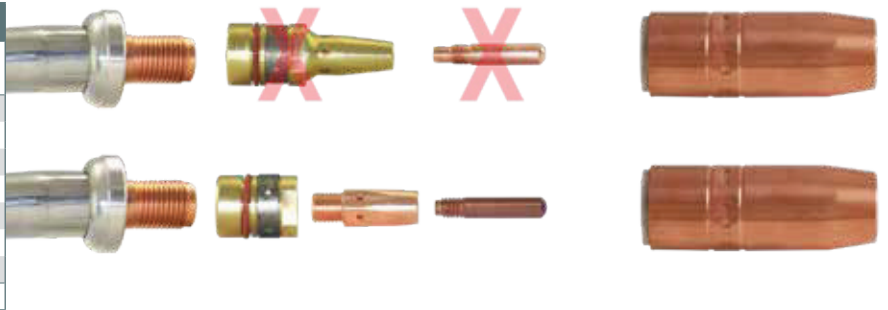

Item	Tough Lock™	Traditional	
Diffuser	404-20, 404-26	404-3	
		403-20-30	403-1-30
		403-20-35	403-1-35
		403-20-45	403-1-45
Contact Tip	403-20-52	403-1-52	
		403-20-116	403-1-116
		403-21-35	403-3-35
		403-21-45	403-3-45
Nozzles	Remain the same		



### Now Change-out is a Breeze with TipRefit®

### Ahora Cambiar es una brisa con TipRefit®

*TipRefit® utilizes Tregaskiss® style consumables with diffusers to convert Lincoln®, Miller®, Bernard® and Tweco® MIG guns to be fitted with Tregaskiss® tips and nozzles. This means that facilities with a mix of MIG guns can reduce inventory and save money.*

*TipRefit® utiliz consumibles estilo Tregaskiss® con difusores para convertir pistolas Lincoln®, Miller®, Bernard® y Tweco® MIG para ser equipados con puntas y boquillas Tregaskiss®. Esta significa que la facilidad de mezcla de pistolas MIG pueden reducir el inventario y ahorrar dinero.*



From De	To A	Part # # Parte
Bernard® Centerfire®	Bernard® Traditional Style (Small)	PRSTRK-B1
	Bernard® Traditional Style (Large)	PRSTRK-B2
	Tregaskiss® Traditional Style	PRSTRK-BT
Tregaskiss® Tough Lock	Tregaskiss® Traditional Style (Standard)	PRSTRK-T1
	Tregaskiss® Traditional Style (Heavy Duty)	PRSTRK-T2
Lincoln® Magnum® Pro/Curve™	Tregaskiss® Traditional Style	PRSTRK-LT
Miller® Rough Neck®	Tregaskiss® Traditional Style	PRSTRK-BT
	Bernard® Traditional Style	PRSTRK-B2
Miller® Traditional	Tregaskiss® Traditional Style	PRSTRK-MT







#	Part#	Description	Descripción	Gun / Pistola
		Gas Diffuser / Difusor de gas		
1	169-716	Gas Diffuser	Difusor de gas	M15
2	169-728	Gas Diffuser	Difusor de gas	M25/25M, M40/40AL
3	169-729	Nozzle Retainer	Retenedor de la boquilla	
		FasTip Gas Diffuser / Difusor de gas FasTip		
4	206195	Gas Diffuser 1/8" Recess	Difusor de gas 1/8" Empotrada	MIG Guns
	206196	Gas Diffuser Flush	Difusor de gas romo	
5	227749	Gas Diffuser 1/8" Recess	Difusor de gas 1/8" Empotrada	Spoolmatic, XR-Pistol
	229670	Gas Diffuser 1/8" Recess	Difusor de gas 1/8" Empotrada	XR-Aluma-Pro

#	Part#	Description	Descripción	Size / Tamaño	Gun / Pistola
		Contact Tips / Puntas de contacto			
6	087-299	Standard	Estándar	.023" (0.6mm)	M15, M25/25M, M40/40AL
	000-067	Standard	Estándar	.030" (0.8mm)	
	000-068	Standard	Estándar	.035" (0.9mm)	
	000-069	Standard	Estándar	.045" (1.2mm)	
	172-024	Standard	Estándar	1/16" (1.6mm)	
	172-025	Standard	Estándar	5/64" (2.0mm)	
	172-034	Standard	Estándar	3/64" (1.2mm)	
7	135-424	Aluminum Wire	Alambre de aluminio	.047" .059"	XR™/XRM™-15A/30A and 15W/30W XR™-Edge and Spoolmatic® 30A/30W
	135-425	Aluminum Wire	Alambre de aluminio	.062" .078"	
	135-426	Steel Wire	Alambre de acero	.062" .073"	
	135-427	Steel Wire	Alambre de acero	.030" .035"	
	135-428	Aluminum Wire	Alambre de aluminio	.030" .040"	
	135-429	Steel Wire	Alambre de acero	.047" .054"	
	135-430	Aluminum Wire	Alambre de aluminio	.035" .050"	
		FasTip Contact Tips / Puntas de contacto FasTip		Steel Wire	Aluminum wire
8	206186	Heavy Duty	Tarea pesada	.035" (0.9mm)	.030" (0.8mm)
	206187	Heavy Duty	Tarea pesada	.040" (1.0mm)	.035" (0.9mm)
	206188	Heavy Duty	Tarea pesada	.045" (1.2mm)	.040" (1.0mm)
	206189	Heavy Duty	Tarea pesada	.052" (1.3mm)	3/64" (1.2mm)
	206190	Heavy Duty	Tarea pesada	1/16" (1.6mm)	
9	209026	Tapered	Ahusadas	.035" (0.9mm)	.030" (0.8mm)
	209027	Tapered	Ahusadas	.045" (1.2mm)	.035" (0.9mm)
	209028	Tapered	Ahusadas	3/64" (1.2mm)	

#	Part#	Description	Descripción	Size / Tamaño	Gun / Pistola
		Nozzles / Boquilla			
10	169-715	Flush	Romo	1/2"	M10, M15
11	169-724	1/8" Recess	1/8" Empotrada	1/2"	
	200-258	Flush	Romo	1/2"	
	169-725	1/8" Recess	1/8" Empotrada	5/8"	M25/25M, M40/40AL
	169-726	Flush	Romo	5/8"	
	169-727	1/8" Stickout	Protuberante de 1/8"	5/8"	
12	050-115	Nozzle	Boquilla	1/2"	Spoolmatic® 1, 2, 3, 30A/XR™'s, XRM's
	050-622	Nozzle	Boquilla	5/8"	
		FasTip Nozzles / Boquilla FasTip			
13	199615	Standard	Estándar	1/2"	Copper
	199613	Standard	Estándar	5/8"	Brass
	198855	Standard	Estándar	5/8"	Copper
	199618	Heavy Duty	Tarea pesada	5/8"	Copper
	199617	Heavy Duty	Tarea pesada	3/4"	Copper
14	209035	Tapered H.D.	Ahusadas uso pesado	3/8"	Copper
	209036	Tapered H.D.	Ahusadas uso pesado	1/2"	Copper

#	Part#	Wire Size Tamaño del cable	Length Longitud	Gun / Pistola
		Liners / Sirga		
15	194-010	.023"-.025"	15'	M10, M15, M25/25M, M40/40AL
	194-011	.030"-.035"	15'	
	194-012	.035"-.045"	15'	
16	136-682	Teflon .023"-.035"	6.75"	XR™-15A, 30A, 15W, 30W / XR™-15A, 30A, 15W, 30W & Spoolmatic®-30A
	136-683	Teflon .045"-1/16"	6.75"	

Victor® Style

#	Part#	Size / Tamaño	Thickness
<b>Victor® 1-101 Medium Preheat / Pre calentamiento medio Acetylene Cutting Tip / Punta de corte acetileno</b>			
1	1-101-000	000	1/8
	1-101-00	00	1/4
	1-101-0	0	1/2
	1-101-1	1	3/4
	1-101-2	2	1 1/2
	1-101-3	3	2 1/2
	1-101-4	4	3
	1-101-5	5	5
	1-101-6	6	8
	1-101-7	7	10
	1-101-8	8	12
CA2460, CA1060, ST, SST, CA350, 1400C, Q2000			
<b>Victor® 1-GPN Medium Preheat / Pre calentamiento medio Propane or Natural Gas / Propano o gas natural</b>			
2	1-GPN-0	0	1/2
	1-GPN-1	1	3/4
	1-GPN-2	2	1 1/2
	1-GPN-3	3	2 1/2
	1-GPN-4	4	3
	1-GPN-5	5	5
	1-GPN-6	6	8
CA2450, CA1060, CAN 1060, ST, SST, STN			
<b>Victor® 1-GPP Medium Preheat / Pre calentamiento medio Propylene / Propileno</b>			
3	1-GPP-00	00	1/4
	1-GPP-0	0	1/2
	1-GPP-1	1	3/4
	1-GPP-2	2	1 1/2
	1-GPP-3	3	2 1/2
	1-GPP-4	4	3
	1-GPP-5	5	5
CA2450, CA1060, CAN 1060, ST, SST, STN			
<b>Victor® 1-118 Gouging / Ranurar Acetylene Cutting Tip / Punta de corte acetileno</b>			
4	1-118-0	0	1/2
	1-118-2	2	1 1/2
	1-118-4	4	3
CA1260, CA1350, C-1450, CA250, CA2060, CA2470, CST 800, C1400			
<b>Victor® 3-101 Medium Preheat / Pre calentamiento medio Acetylene Cutting Tip / Punta de corte acetileno</b>			
5	3-101-00	00	1/4
	3-101-0	0	1/2
	3-101-1	1	3/4
	3-101-2	2	1 1/2
	3-101-3	3	2 1/2
	3-101-4	4	3
CA1260, CA1350, C-1450, CA250, CA2060, CA2470, CST 800, C1400			
<b>Victor® 3-GPN Medium Preheat / Pre calentamiento medio Propane or Natural Gas / Propano o gas natural</b>			
6	3-GPN-00	00	1/4
	3-GPN-0	0	1/2
	3-GPN-1	1	3/4
	3-GPN-2	2	1 1/2
	3-GPN-3	3	2 1/2
	3-GPN-4	4	3
CA1260, CA1350, C-1450, CA250, CA2060, CA2470, CST 800, C1400			
<b>Victor® 3-GPP Medium Preheat / Pre calentamiento medio Propylene / Propileno</b>			
7	3-GPP-00	00	1/4
	3-GPP-0	0	1/2
	3-GPP-1	1	3/4
	3-GPP-2	2	1 1/2
	3-GPP-3	3	2 1/2
CA1260, CA1350, C-1450, CA250, CA2060, CA2470, CST 800, C1400			



Airco® Style

#	Part#	Size / Tamaño	Thickness
<b>Airco® 144 Medium Preheat / pre calentamiento medio Acetylene Cutting Tip / Punta de corte acetileno</b>			
10	144-00	00	1/8
	144-0	0	1/4
	144-1	1	3/8
	144-2	2	3/4
	144-3	3	1 1/2
	144-4	4	2 1/2
	144-5	5	3
	144-6	6	6
	144-8	8	8
3790, 4690, 4700, 4800, 5700, 5800, 1100, 3000, 9000, 9500			
<b>Airco® 164 Very Heavy Preheat / Pre calentamiento muy pesado Acetylene Cutting Tip / Punta de corte acetileno</b>			
11	164-00	00	1/8
	164-0	0	5/16
	164-1	1	1/2
	164-2	2	1
	164-3	3	1 3/4
	164-4	4	2 1/2
3790, 4690, 4700, 4800, 5700, 5800, 1100, 3000, 9000, 9500			
<b>Airco® 164 Heavy Preheat / Pre calentamiento pesado Propane or Natural Gas / Propano o gas natural</b>			
12	261-2	2	3/4
3790, 4690, 4700, 4800, 5700, 5800, 1100, 3000, 9000, 9500			



Victor® Style Heating Tips

#	Part#	Size / Tamaño	Series
<b>Medium Duty / Tarea mediana Acetylene / Acetileno</b>			
8	8-MFA	8	300
9	6-MFA-1	6	100



### Harris® Style

#	Part#	Size / Tamaño	Thickness
<b>Harris® 6290 Medium Preheat / Pre calentamiento medio Acetylene Cutting Tip / Punta de corte acetileno</b>			
1	6290-000	000	3/16
	6290-00	00	3/16 - 3/8
	6290-0	0	3/8 - 5/8
	6290-1	1	5/8 - 1
	6290-2	2	1 - 2
	6290-3	3	2 - 3
	6290-4	4	3 - 6
	6290-5	5	6 - 8
	73, 49, 273, 72, 36 62, 242, 42		
<b>Harris® 6290S Heavy Preheat / Pre calentamiento pesado Acetylene Cutting Tip / Punta de corte acetileno</b>			
2	6290-5S	5	6 - 8
	6290-6S	6	8 - 12
	73, 49, 273, 72, 36 62, 242, 42		
<b>Harris® 6290NFF Heavy Preheat / Pre calentamiento pesado Propane or Natural Gas / Propano o gas natural</b>			
3	6290-NFF-1	1	5/8 - 1
	6290-NFF-2	2	1 - 2
	6290-NFF-3	3	2 - 3
	6290-NFF-4	4	3 - 6
	6290-NFF-5	5	6 - 8
	6290-NFF-6	6	8 - 12
	73, 49-F, V49-3F, 273, 72, 36 62, 242, 42		
<b>Harris® 6290NX Medium Preheat / Pre calentamiento medio Propane or Natural Gas / Propano o gas natural</b>			
4	6290-NX-1	1	5/8 - 1
	6290-NX-2	2	1 - 2
	6290-NX-3	3	2 - 3
	6290-NX-4	4	3 - 6
	6290-NX-5	5	6 - 8
	6290-NX-6	6	8 - 12
	73, 49-F, V49-3F, 273, 72, 36 62, 242, 42		
<b>Harris® 6290NXP Medium Preheat / Pre calentamiento medio Propylene / Propileno</b>			
5	6290-NXP-00	00	3/16 - 3/8
	6290-NXP-0	0	3/8 - 5/8
	6290-NXP-1	1	5/8 - 1
	6290-NXP-2	2	1 - 2
	6290-NXP-3	3	2 - 3
	6290-NXP-4	4	3 - 6
	49-3F, 49-3AF, 39-3F 62-5F, 62-5AF, 880-F, 142-F		
<b>Harris® 6290VVC High Speed / Alta velocidad Propylene / Propileno</b>			
6	6290-VVC-000	000	3/8
	6290-VVC-00	00	1/2
	6290-VVC-0	0	3/4
	6290-VVC-1/2	1/2	1 1/4
	6290-VVC-1	1	2
	6290-VVC-1 1/2	1 1/2	3
	6290-VVC-2	2	4
	6290-VVC-3	3	6
	6290-VVC-4	4	8
	6290-VVC-5	5	9
	598C-1200080, BV98-1200124, TH98-1200090 98-6, 98-3		
<b>Harris® 6290VVCU High Speed / Alta velocidad Propylene / Propileno</b>			
7	6290-VVCU-000	000	3/8
	6290-VVCU-00	00	1/2
	6290-VVCU-0	0	3/4
	6290-VVCU-1/2	1/2	1 1/4
	6290-VVCU-1	1	2
	6290-VVCU-1 1/2	1 1/2	3
	6290-VVCU-2	2	4
	6290-VVCU-3	3	6
	6290-VVCU-4	4	8
	598C-1200080, BV98-1200124, TH98-1200090 98-6, 98-3		

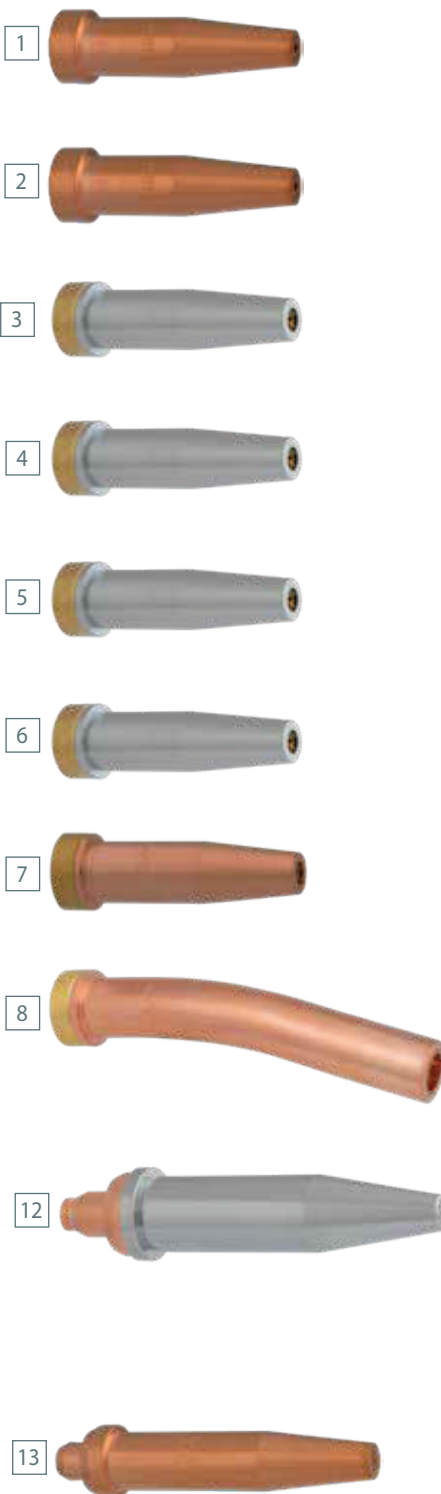

### Harris® Style

#	Part#	Size / Tamaño
<b>Harris® 6290 GG Gouging / Ranurar Propane or Natural Gas / Propano o gas natural</b>		
8	6290-GG-2	2
	6290-GG-3	3

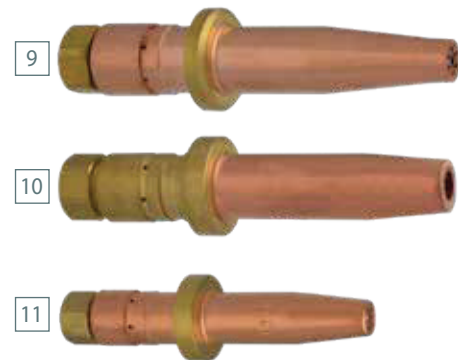

### Smith® Style

#	Part#	Size / Tamaño	Thickness
<b>Smith® MC12 Medium Preheat / Pre calentamiento medio Acetylene Cutting Tip / Punta de corte acetileno</b>			
9	MC12-0	0	3/8
	MC12-1	1	5/8
	MC12-2	2	1 1/4
	MC12-3	3	2
	MC12-4	4	4
	MC505, MC509, AC305, AC309		
<b>Smith® SC12 Medium Preheat / Pre calentamiento medio Propane or Natural Gas / Propano o gas natural</b>			
10	SC12-00	00	3/16
	SC12-1	1	5/8
	SC12-2	2	1 1/4
	SC12-3	3	2
	SC12-4	4	4
	SC12-5	5	8
	MC409, SC170, SC200, SC220, SC270, SC360, SC720, SC730, SC770, SC771, SC780, SC780A, SC781A, SC782A, SC850, SC860, SC890		
<b>Smith® SC50 Heavy Preheat / Pre calentamiento pesado Propane or Natural Gas / Propano o gas natural</b>			
11	SC50-1	1	5/8
	SC50-2	2	1 1/4
	SC50-3	3	2
	SC50-4	4	4
	SC50-5	5	8
	SC50-6	6	12
	MC409, SC170, SC200, SC220, SC270, SC360, SC720, SC730, SC770, SC771, SC780, SC780A, SC781A, SC782A, SC850, SC860, SC890		

### Oxweld® Style

#	Part#	Size / Tamaño	Thickness
<b>Oxweld® 1502 Medium Preheat / Pre calentamiento medio Acetylene Cutting Tip / Punta de corte acetileno</b>			
12	1502-3	3	1/4
	1502-4	4	1/2
	1502-6	6	1 1/2
	1502-8	8	4
	CW-32, C-31, C-23, C-77, C-37, C-39, C-58		

### Purox/L-Tec® Style

NO.	Part#	Size / Tamaño	Thickness
<b>Purox/L-Tec® 4202 Medium Preheat / Pre calentamiento medio Acetylene Cutting Tip / Punta de corte acetileno</b>			
13	4202-2	2	1/8
	4202-3	3	1/4
	4202-4	4	5/8
	4202-5	5	1 1/2
	4202-7	7	4
	4202-9	9	6
	4202-11	11	
	C-205, CW-300		



Oxy-fuel Accessories

Accesorios de Oxy-fuel

#	Part #	Description	Descripción
1	08-101	Bug Lighter	Encendedor
2	KH570	Single Flint Striker	Pedernal soltero
3	KH571	Replacement Single Flint, 5ea	Reemplazo de pedernal soltero, 5ea
4	KH572	Triple Flint Striker	Pedernal triple
5	KH573	Replacement Triple Flint, 4ea	Reemplazo de pedernal triple, 4ea
6	KH575	Tip Cleaner, 13 Files 3"	Limpiador de puntas, 13 limas de 3"
	KH574	Tip Cleaner, 13 Files 4"	Limpiador de puntas, 13 limas de 4"
7	1014	Cylinder Wrench	Llave de cilindro

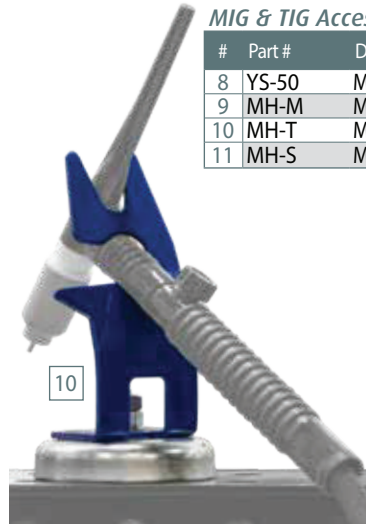

MIG & TIG Accessories

Accesorios de MIG y TIG

#	Part #	Description	Descripción
8	YS-50	MIG Pliers	Alicates MIG
9	MH-M	Magnetic MIG Gun Holder	Soporte magnético de pistola MIG
10	MH-T	Magnetic TIG Torch Holder	Soporte magnético de antorcha TIG
11	MH-S	Magnetic Stinger Holder	Soporte magnético de portaelectrodos



Chipping Hammer

Martillo Cincelador

#	Part #	Description	Descripción
12	S-20	Chipping Hammer, Steel Handle	Martillo cincelador, mango de acero





**Tweco® Style Cable Connectors**

**Conectores del Cable de estilo Tweco®**

#	Part #	Description	Descripción
1+2	1-MBP	Set Male & Female, 200 Amp For #4, #3, #2, #1 Cable	Conjunto varón y hembra, 200A para #4, #3, #2, #1 Cable
1	1-MBP-1	Male Only, 200 Amp For #4, #3, #2, #1 Cable	Solo varón, 200A para #4, #3, #2, #1 Cable
2	1-MBP-2	Female only, 200 Amp For #4, #3, #2, #1 Cable	Solo hembra, 200A para #4, #3, #2, #1 Cable
3+4	2-MBP	Set Male & Female, 300 Amp For #1/0, #2/0, #3/0 Cable	Conjunto varón y hembra, 300A para #1/0, #2/0, #3/0 Cable
3	2-MBP-1	Male Only, 300 Amp For #1/0, #2/0, #3/0 Cable	Solo varón, 300A para #1/0, #2/0, #3/0 Cable
4	2-MBP-2	Female only, 300 Amp For #1/0, #2/0, #3/0 Cable	Solo hembra, 300A para #1/0, #2/0, #3/0 Cable
5	40037	Dinse Adapter 50mm Female to 25mm Male	Adaptador dinse, 50mm hembra a 25mm varón



**Ground Clamps**

**Pinzas de Tierra**

#	Part #	Description	Descripción
6	SGC-300	Steel Ground Clamp 300 Amp	Pinza de Tierra de Acero, 300A
	SGC-500	Steel Ground Clamp 500 Amp	Pinza de Tierra de Acero, 500A
7	GC-300	Tweco® Style Copper Ground Clamp 300 Amp	Pinza de Tierra de cobre de estilo Tweco®, 300A
	GC-500	Tweco® Style Copper Ground Clamp 500 Amp	Pinza de Tierra de cobre de estilo Tweco®, 500A
8	FGC-300	Tweco® Style Flat Copper Ground Clamp 300 Amp	Pinza de Tierra plana de cobre de estilo Tweco®, 300A
	FGC-500	Tweco® Style Flat Copper Ground Clamp 500 Amp	Pinza de Tierra plana de cobre de estilo Tweco®, 500A



**Cable Lugs**

**Terminales de Cable**

#	Part #	Description	Descripción	Wire Size	Stud Hole
9	T-62	Crimp or Solder	Prensar o soldar	#6 - #2	
	T-120	Crimp or Solder	Prensar o soldar	#1 - #2/0	
	T-3040	Crimp or Solder	Prensar o soldar	#3/0 - #4/0	
10	HL-1020	Hammer-On	Martillar sobre	#1 - #2/0	
	HL-3040	Hammer-On	Martillar sobre	#3/0 - #4/0	

**Electrode Holders**

**Portaelectrodos**

#	Part #	Description	Descripción
11	A-532	Tweco® Style 200 Amp	Estilo Tweco®, 200A
12	A-316	Tweco® Style 250 Amp	Estilo Tweco®, 250A
	A-732	Tweco® Style 300 Amp	Estilo Tweco®, 300A
13	40B	Bernard® Style 400 Amp	Estilo Bernard®, 400A



# GOUGING TORCH

1000 Amp Available Torches & Parts Breakdown

# ANTORCHA PARA RANURAR

Antorchas 1000 A disponibles y Desglose de Partes

Part#	Description	Descripción
01-082-002	4000 Torch Only	Sólo la antorcha 4000
61-082-008	4000 Torch with 7ft Cable	Antorcha y cable de 7 pies
61-082-009	4000 Torch with 10ft Cable	Antorcha y cable de 10 pies

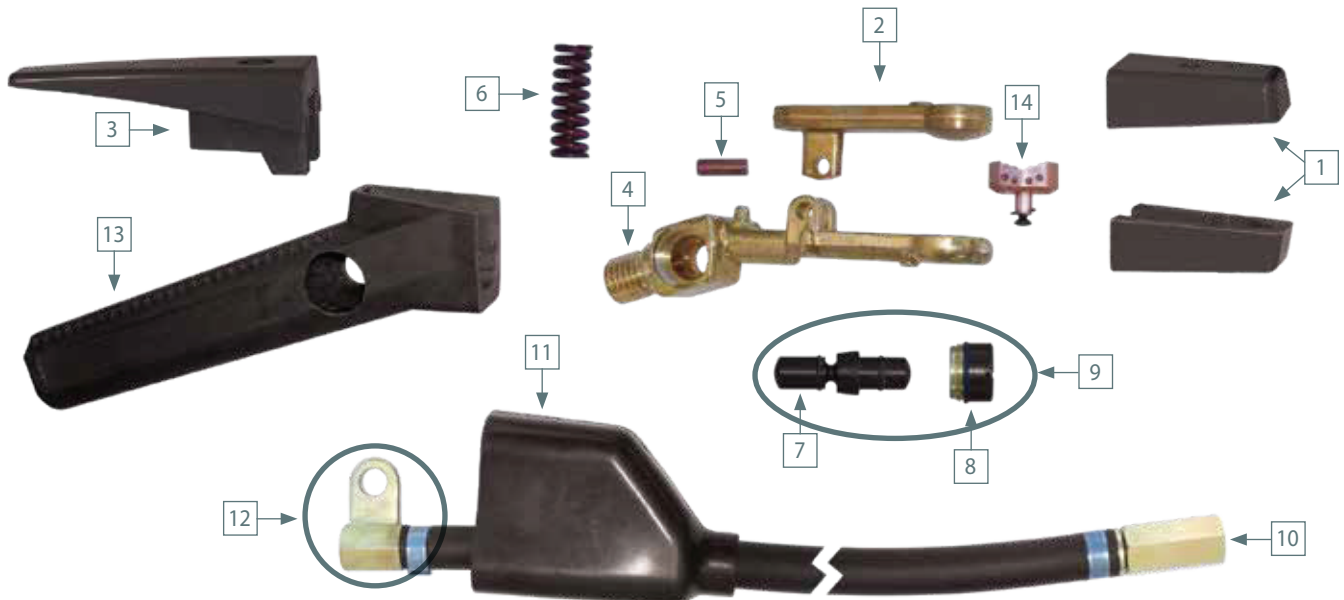

#	Part#	Description	Descripción	Part#	Description	Descripción	
1	94-433-183	Insulator Assembly	Montaje aislante	8	94-104-012	Bonnet	Capa
2	94-048-088	Upper Arm	Brazo alto	9	94-104-016	Valve & Bonnet	Válvula y capa
3	94-476-066	Lever Assembly	Montaje la palanca	10	70-084-207	7' Cable Assembly	Montaje del cable de 7 pies
4	94-103-206	Torch Body	Cuerpo de la antorcha		70-084-210	10' Cable Assembly	Montaje del cable de 10 pies
5	94-632-094	Hinge Pin	Perno de la bisagra	11	94-105-014	Insulating Boot	Bota aislante
6	94-800-077	Spring	Resorte	12	94-170-150	Air-Power Connector	Conector con potencia de air
7	94-801-011	Valve with O-Rings	Válvula con anillos O	13	94-370-163	Handle	Empuñadura
	94-710-036	O-Rings	Anillos O	14	94-378-368	Head & Screw	Cabeza y tornillo



**BRIGHTON-BEST**  
**INTERNATIONAL**



- New formula all synthetic graphite
- Available in all common sizes
- Superb arc starting and stability
- Uniform diameters

- Nueva fórmula todo grafito sintético
- Disponible en todos los tamaños comunes
- Arranque de arco magnífico y estabilidad
- Diámetros uniformes

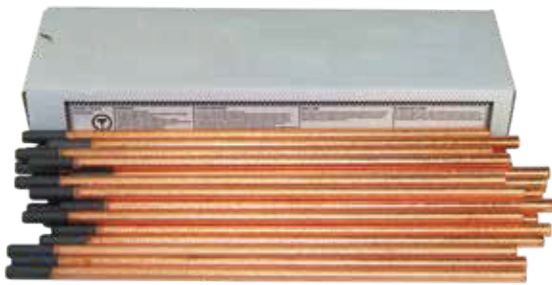

Part#	Size / Tamaño	Qty./Cant
<b>Pointed / Puntados</b>		
22-023-003	1/8" x 12" (3.2mm x 305mm)	100
22-983-003	5/32" x 12" (4.0mm x 305mm)	50
22-033-003	3/16" x 12" (5.0mm x 305mm)	50
22-043-003	1/4" x 12" (6.5mm x 305mm)	50
22-053-003	5/16" x 12" (8.0mm x 305mm)	50
22-063-003	3/8" x 12" (9.5mm x 305mm)	50
22-082-003	1/2" x 14" (13.0mm x 355mm)	50
<b>Jointed / Juntados</b>		
24-064-003	3/8" x 17" (9.5mm x 430mm)	100
24-084-003	1/2" x 17" (13.0mm x 430mm)	100
24-104-003	5/8" x 17" (16.0mm x 430mm)	100
24-124-003	3/4" x 17" (19.0mm x 430mm)	100
<b>Hollow / Huecos</b>		
22-033-003HC	3/16" x 12" (5.0mm x 305mm)	50
22-043-003HC	1/4" x 12" (6.5mm x 305mm)	50
22-053-003HC	5/16" x 12" (8.0mm x 305mm)	50
22-063-003HC	3/8" x 12" (9.5mm x 305mm)	50
<b>Flat / Planas</b>		
35-099-003	9.5 x 4.0 x 305 mm (3/8 x 5/32 x 12")	50
35-033-003	19.0 x 5.0 x 305 mm (5/8 x 3/16 x 12")	50

- Solid heavy duty aluminum housing
- Comes with stainless steel work table
- Replaceable bottle collects grinding dust
- Longitudinal grinding of electrode
- Stick-out adjustment reduces electrode waste

- Alojamiento de aluminio, sólido para trabajo pesado
- Viene con mesa de trabajo de acero inoxidable
- Botella reemplazable para recoger el polvo de molienda
- Longitudinal molienda del electrodo
- Ajustador para sobrante reduce el desperdicio de electrodos

88897030

Wet Tungsten Grinder  
Amoladora Húmeda de Tungsteno



88897530

Wet Tungsten Grinder/Cutter  
Amoladora Húmeda de Tungsteno / cortadora

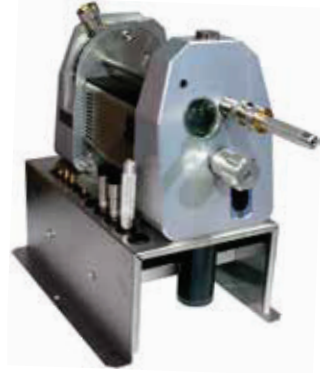

The Grinder/Cutter cutting chamber lets you cut electrodes lengths from 5/16" to 6 1/8"

La Cortadora Amoladora permite cortar longitudes de electrodos de 5/16" a 6 1/8"

Part#	Description	Comes With	Descripción	Viene con:
88897030	Wet Tungsten Grinder	<ul style="list-style-type: none"> <li>• Electrode Holder</li> <li>• 1/16", 3/32", 1/8" Electrode Clamps</li> <li>• Cooling Liquid</li> <li>• Grinder Stand</li> </ul>	Amoladora de Tungsteno húmeda	<ul style="list-style-type: none"> <li>• Porta electrodos</li> <li>• 1/16", 3/32", 1/8" Mordazas</li> <li>• Líquido de enfriamiento</li> <li>• Soporte de la amoladora</li> </ul>
88897530	Wet Tungsten Grinder/Cutter	<ul style="list-style-type: none"> <li>• Electrode Holder</li> <li>• 1/16", 3/32", 1/8" Electrode Clamps</li> <li>• 1/16", 3/32", 1/8" Cut-off Collets</li> <li>• Cut-off Collet tool</li> <li>• 2 Cut-off Tools</li> <li>• Cooling Liquid</li> <li>• Grinder Stand</li> </ul>	Amoladora de Tungsteno húmeda cortadora	<ul style="list-style-type: none"> <li>• Porta electrodos</li> <li>• 1/16", 3/32", 1/8" Mordaza</li> <li>• 1/16", 3/32", 1/8" Cortador para mordazas</li> <li>• Herramienta cortadora para mordaza</li> <li>• Dos herramientas cortadoras</li> <li>• Líquido de enfriamiento</li> <li>• Soporte para amoladora</li> </ul>

- Grinds Tungsten from 15° to 180° (Included Angle)

- Muele tungsteno de 15° a 180° ángulo incluido



### Commonly Ordered Spare Parts for Wet Grinders Piezas de repuesta comúnmente ordenados

Part #	Description	Descripción
44490512	Diamond Grinding Wheel	Rueda amoladora de diamante
44490520	Diamond Cut-off Wheel (Grinder/Cutter)	Rueda de corte de diamante (molinillo / cortador)
W95/1-12	Grinding Liquid 8 oz Bottle	Botella de Líquido para moliendo
44510162	1/16" Electrode Clamp	1/16" Abrazadera del electrodo
44510164	3/32" Electrode Clamp	3/32" Abrazadera del electrodo
44510165	1/8" Electrode Clamp	1/8" Abrazadera del electrodo
W95/1-45	Liquid Containing Dust Receiving Bottle	Botella de Líquido para residuo
W95/1-07	Inspection Cover	Cobertura de inspección
W95/1-10	Gasket for Inspection Cover	Gásquet para cobertura de inspección





- Portable tungsten grinding system means less welding down time.
- Enclosed grinding system protects the welder and the environment.
- Correct electrode grain direction and automatic collection of grinding dust.
- Multiple grinding positions ensure long grinding wheel life.

- Sistema portátil de moliendo tungsteno significa menos tiempo de inactividad de soldadura.
- Sistema de moliendo cerrado para proteger al soldador y el medio ambiente.
- Dirección correcta la molienda del electrodo y la recolección automática de polvo de amolado.
- Múltiples posiciones de molienda garantizan una larga vida de muelas.

Part#	Description	Comes With	Descripción	Viene con:
88896022	Select Portable Tungsten Grinder	• Electrode Holder• Wrenches • 1/16", 3/32", 1/8" Electrode Clamp	Amoladora de tungsteno portátil	• Portaelectrodos• Llaves • 1/16", 3/32", 1/8" Abrazadera del electrodo

### Commonly Ordered Spare Parts Piezas de repuesto comúnmente ordenadas

Part #	Description	Descripción
44510030	Diamond Grinding Wheel	Rueda amoladora de diamante
44510260	Filter Cassette	Casete filtro
44510162	1/16" Electrode Clamp	1/16" Abrazadera del electrodo
44510164	3/32" Electrode Clamp	3/32" Abrazadera del electrodo
44510165	1/8" Electrode Clamp	1/8" Abrazadera del electrodo
44510290	Inspection Cover	Cobertura de inspección
44510174	5/32" Electrode Clamp	5/32" Abrazadera del electrodo

Stick-out Adjustment ensures minimal loss of tungsten

Ajustador para sobrante asegura una mínima pérdida de tungsteno







Engineered blend of oxides outperforms other electrode types.  
The long life tungsten electrode.

- Best choice to replace thoriated electrodes
- Longer life
- Non-radioactive additives
- Proven to outperform other electrodes
- Can be used in both DC & AC processes
- Stable tip and arc geometry
- Every electrode is Eddy Current tested for defects

Mezcla de óxidos de ingeniería supera a otros tipos de electrodos.  
La larga vida de electrodos de tungsteno

- La mejor opción para sustituir los electrodos toriados
- una vida más larga
- No aditivos radiactivos
- A demostrado superar otros electrodos
- Puede ser utilizado tanto en los procesos de DC y AC
- Punta y geometría del arco estables
- Cada electrodo fue probado Eddy Current para eliminar defectos

Part#	Size / Tamaño	Length/Longitud
<b>2% Ceriated/Ceridado</b>		
020-7GC2	.020" (0.5mm)	7" (175mm)
040-7GC2	.040" (1.0mm)	7" (175mm)
116-3GC2	1/16" (1.6mm)	3" (75mm)
116-7GC2	1/16" (1.6mm)	7" (175mm)
332-3GC2	3/32" (2.4mm)	3" (75mm)
332-7GC2	3/32" (2.4mm)	7" (175mm)
332-12GC2	3/32" (2.4mm)	12" (305mm)
332-18GC2	3/32" (2.4mm)	18" (457mm)
18-3GC2	1/8" (3.2mm)	3" (75mm)
18-7GC2	1/8" (3.2mm)	7" (175mm)
18-12GC2	1/8" (3.2mm)	12" (305mm)
18-18GC2	1/8" (3.2mm)	18" (457mm)
18-24GC2	1/8" (3.2mm)	24" (610mm)
532-7GC2	5/32" (4.0mm)	7" (175mm)
316-7GC2	3/16" (4.8mm)	7" (175mm)
316-18GC2	3/16" (4.8mm)	18" (457mm)
14-7GC2	1/4" (6.4mm)	7" (175mm)
14-12GC2	1/4" (6.4mm)	12" (305mm)
14-18GC2	1/4" (6.4mm)	18" (457mm)

Part#	Size / Tamaño	Length/Longitud
<b>2% Lanthanum/Lanthano</b>		
040-7GL2	.040" (1.0mm)	7" (175mm)
116-7GL2	1/16" (1.6mm)	7" (175mm)
332-7GL2	3/32" (2.4mm)	7" (175mm)
18-7GL2	1/8" (3.2mm)	7" (175mm)
532-7GL2	5/32" (4.0mm)	7" (175mm)
316-7GL2	3/16" (4.8mm)	7" (175mm)
14-7GL2	1/4" (6.4mm)	7" (175mm)



Part#	Size / Tamaño	Length/Longitud
<b>1.5% Lanthanum/Lanthano</b>		
020-7GL	.020" (0.5mm)	7" (175mm)
040-7GL	.040" (1.0mm)	7" (175mm)
116-3GL	1/16" (1.6mm)	3" (75mm)
116-7GL	1/16" (1.6mm)	7" (175mm)
332-3GL	3/32" (2.4mm)	3" (75mm)
332-7GL	3/32" (2.4mm)	7" (175mm)
332-18GL	3/32" (2.4mm)	18" (457mm)
18-3GL	1/8" (3.2mm)	3" (75mm)
18-7GL	1/8" (3.2mm)	7" (175mm)
532-7GL	5/32" (4.0mm)	7" (175mm)
316-3GL	3/16" (4.8mm)	3" (75mm)
316-7GL	3/16" (4.8mm)	7" (175mm)
316-18GL	3/16" (4.8mm)	18" (457mm)
14-7GL	1/4" (6.4mm)	7" (175mm)

Part#	Size / Tamaño	Length/Longitud
<b>E3</b>		
020-7E3	.020" (0.5mm)	7" (175mm)
040-7E3	.040" (1.0mm)	7" (175mm)
116-3E3	1/16" (1.6mm)	3" (75mm)
116-7E3	1/16" (1.6mm)	7" (175mm)
116-12E3	1/16" (1.6mm)	12" (305mm)
116-18E3	1/16" (1.6mm)	18" (457mm)
332-3E3	3/32" (2.4mm)	3" (75mm)
332-7E3	3/32" (2.4mm)	7" (175mm)
332-12E3	3/32" (2.4mm)	12" (305mm)
332-18E3	3/32" (2.4mm)	18" (457mm)
18-3E3	1/8" (3.2mm)	3" (75mm)
18-7E3	1/8" (3.2mm)	7" (175mm)
18-12E3	1/8" (3.2mm)	12" (305mm)
18-18E3	1/8" (3.2mm)	18" (457mm)
18-24E3	1/8" (3.2mm)	24" (610mm)
532-7E3	5/32" (4.0mm)	7" (175mm)
532-12E3	5/32" (4.0mm)	12" (305mm)
532-18E3	5/32" (4.0mm)	18" (457mm)
316-7E3	3/16" (4.8mm)	7" (175mm)
316-12E3	3/16" (4.8mm)	12" (305mm)
316-18E3	3/16" (4.8mm)	18" (457mm)
14-7E3	1/4" (6.4mm)	7" (175mm)

Part#	Size / Tamaño	Length/Longitud
<b>Pure/Puro</b>		
020-3G	.020" (0.5mm)	3" (75mm)
020-7G	.020" (0.5mm)	7" (175mm)
040-7G	.040" (1.0mm)	7" (175mm)
040-12G	.040" (1.0mm)	12" (305mm)
116-3G	1/16" (1.6mm)	3" (75mm)
116-7G	1/16" (1.6mm)	7" (175mm)
332-3G	3/32" (2.4mm)	3" (75mm)
332-7G	3/32" (2.4mm)	7" (175mm)
18-3G	1/8" (3.2mm)	3" (75mm)
18-7G	1/8" (3.2mm)	7" (175mm)
532-7G	5/32" (4.0mm)	7" (175mm)
532-7G	5/32" (4.0mm)	12" (305mm)
316-7G	3/16" (4.8mm)	7" (175mm)
14-3G	1/4" (6.4mm)	3" (75mm)
14-7G	1/4" (6.4mm)	7" (175mm)

Part#	Size / Tamaño	Length/Longitud
<b>Zirconium/ Zirconio</b>		
020-3GZ	.020" (0.5mm)	3" (75mm)
020-7GZ	.020" (0.5mm)	7" (175mm)
040-3GZ	.040" (1.0mm)	3" (75mm)
040-7GZ	.040" (1.0mm)	7" (175mm)
116-3GZ	1/16" (1.6mm)	3" (75mm)
116-7GZ	1/16" (1.6mm)	7" (175mm)
332-3GZ	3/32" (2.4mm)	3" (75mm)
332-7GZ	3/32" (2.4mm)	7" (175mm)
18-3GZ	1/8" (3.2mm)	3" (75mm)
18-7GZ	1/8" (3.2mm)	7" (175mm)
532-3GZ	5/32" (4.0mm)	3" (75mm)
532-7GZ	5/32" (4.0mm)	7" (175mm)
316-3GZ	3/16" (4.8mm)	3" (75mm)
316-7GZ	3/16" (4.8mm)	7" (175mm)
14-7GZ	1/4" (6.4mm)	7" (175mm)



- *The Modular Advantage is weld-joint accessibility*
  - *Air-cooled kits have 20 possible configurations*
  - *Kits come with tungsten and consumables*
  - *Reusable attache case with programmable locks*
  - *Super flexible nylon braided hoses*
  - *Each kit comes with 5 unique interchangeable torch heads*
- 
- *La ventaja modular es la accesibilidad a la soldadura conjunta.*
  - *Los kits refrigerados por aire cuentan con 20 configuraciones diferentes.*
  - *Los kits también vienen con tungsteno y consumibles.*
  - *Maletín reutilizable con cerraduras programables.*
  - *Mangueras super flexibles, trenzadas de nylon.*
  - *Cada kit viene con 5 cabezas de antorcha únicas intercambiables.*



1 Kit with 20 Combinations

1 kit con 20 Combinaciones



Part #	Description	Descripción
M-150-R	150 Amp Air-Cooled TIG Torch Kit	Kit de la antorcha 150A, refrigerado por aire
Each Kit Includes		Cada kit incluye
1	150 Amp Air-Cooled Torch Pkg, 25	1 Paquete de la antorcha, 25
5	Modular Torch Heads	5 Cabezal de la antorcha modular
2	Torch Bodies, With and Without Valve	2 Cuerpos de la antorcha con y sin válvula
2	Elements, Flex Coil and Solid	2 Elementos bobina flexible y solido
1	Consumables Kit with Collets, Collet Bodies, Nozzles and Back Caps to Fit all Heads and Tungsten Sizes .040, 1/16 " & 3/32 "	1 Kit de consumibles con mordazas, portamordazas, boquillas y tapas traseras para todos los cabezales y medidas de tungsteno .040, 1/16 " & 3/32 "
1	Tungsten Kit with E3 Tungsten Sizes .040, 1/16 " & 3/32 " 2 Each	1 Kit de tungsteno con E3 tungstenos E3 de medidas .040", 1/16 " & 3/32 "
2	Wrenches	2 Llaves
1	Reusable Aluminum Attaché Case	1 Maleta de aluminio reutilizable
M-200-R	200 Amp Air-Cooled TIG Torch Kit	Kit de la antorcha 200A, refrigerado por aire
Each Kit Includes		Cada kit incluye
1	200 Amp Air-Cooled Torch Pkg, 25	1 Paquete de la antorcha, 25
5	Modular Torch Heads	5 Cabezal de la antorcha modular
2	Torch Bodies, With and Without Valve	2 Cuerpos de la antorcha con y sin válvula
2	Elements, Flex Coil and Solid	2 Elementos bobina flexible y solido
1	Consumables Kit with Collets, Collet Bodies, Nozzles and Back Caps to Fit all Heads and Tungsten Sizes 1/16", 3/32 " & 1/8"	1 Kit de consumibles con mordazas, portamordazas, boquillas y tapas traseras para todos los cabezales y medidas de tungsteno .040, 1/16 " & 3/32 "
1	Tungsten Kit with E3 Tungsten Sizes 1/16", 3/32 " & 1/8", 2 Each	1 Kit de tungsteno con E3 tungstenos E3 de medidas 1/16", 3/32 ", 1/8"
2	Wrenches	2 Llaves
1	Reusable Aluminum Attaché Case	1 Maleta de aluminio reutilizable
M-225-R	225 Amp Water-Cooled TIG Torch Kit	Kit de la antorcha 225A, refrigerado por agua
Each Kit Includes		Cada kit incluye
1	225 Amp Water-Cooled Torch Pkg, 25	1 Paquete de la antorcha, 25
5	Modular Torch Heads	5 Cabezal de la antorcha modular
1	Consumables Kit with Collets, Collet Bodies, Nozzles and Back Caps to Fit all Heads and Tungsten Sizes 1/16", 3/32 " & 1/8 "	1 Kit de consumibles con mordazas, portamordazas, boquillas y tapas traseras para todos los cabezales y medidas de tungsteno 1/16", 3/32 ", 1/8"
1	Tungsten Kit with E3 Tungsten Sizes 1/16", 3/32 " & 1/8", 2 Each	1 Kit de tungsteno con E3 tungstenos E3 de medidas 1/16", 3/32 ", 1/8"
1	Reusable Aluminum Attaché Case	1 Maleta de aluminio reutilizable

# 150M SERIES TIG

## 150 Amp Air-Cooled Torches Torch Packages & Parts Breakdown

# SERIE 150M TIG

## 150 A antorchas refrigeradas por aire Ensamblajes de antorchas y desglose de piezas

### Available TIG Torches

### Antorchas TIG disponibles

Part#	Description	Descripción	Part#	Description	Descripción
150M	Flex Torch 150 Amp	Antorcha Flexible 150A	150VM	Flex Torch with Valve 150 Amp	Antorcha Flex con válvula 150 A
150M-12-2	Torch Package, 12.5' 2pc.	Ensamblaje de antorcha, 12.5' 2pc.	150VM-12-2	Torch Package, 12.5' 2pc.	Ensamblaje de antorcha, 12.5' 2pc.
150M-12-R	Torch Package, 12.5' 1pc.	Ensamblaje de antorcha, 12.5' 1pc.	150VM-12-R	Torch Package, 12.5' 1pc.	Ensamblaje de antorcha, 12.5' 1pc.
150M-25-2	Torch Package, 25' 2pc.	Ensamblaje de antorcha, 25' 2pc.	150VM-25-2	Torch Package, 25' 2pc.	Ensamblaje de antorcha, 25' 2pc.
150M-25-R	Torch Package, 25' 1pc.	Ensamblaje de antorcha, 25' 1pc.	150VM-25-R	Torch Package, 25' 1pc.	Ensamblaje de antorcha, 25' 1pc.

Torch Package Includes: Torch Body, Flex Element, Solid Element, Power Cable, Handle, 9-70M Head, 1726M Head & Wrench  
El ensamblaje de la antorcha incluye: Cuerpo de la antorcha, elemento flexible, elemento sólido, cable de alimentación, empuñadura, las cabezas 9-70M y 1726M, y llave inglesa

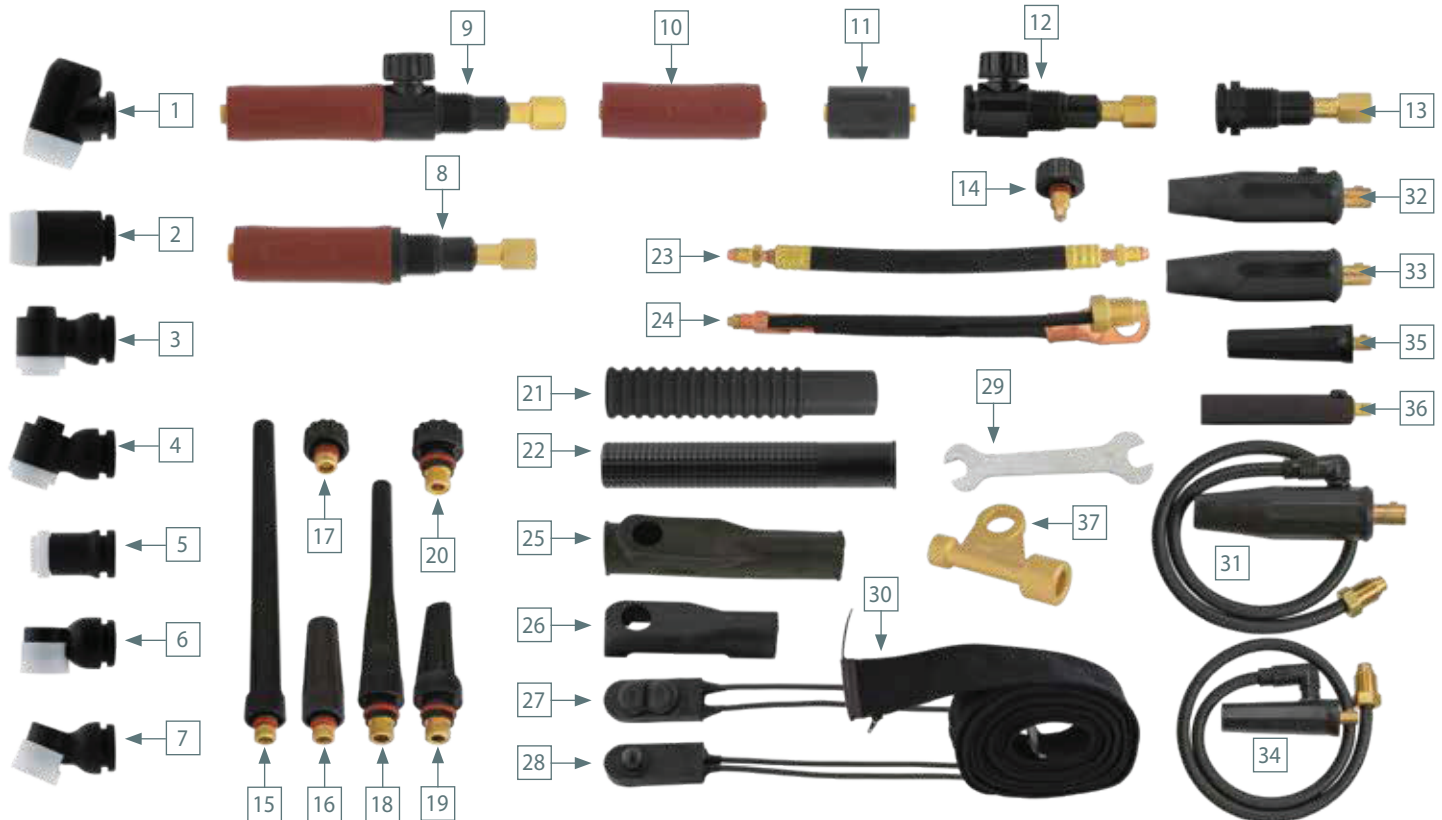

#	Part#	Description	Descripción	#	Part#	Description	Descripción
1	1726M	Torch Head, 150A 70°	Cabezal de la antorcha 150A 70°	22	105Z55	Smooth Handle	Empuñadura lisa
2	1726PM	Torch Head, 150A 180°	Cabezal de la antorcha, 150A 180°	23	57Y01R	Power Cable, Rubber, 12.5'	Cable de alimentación, goma, 12.5'
3	9-90M	Torch Head, 125A 90°	Cabezal de la antorcha, 125A 90°	57Y03R	Power Cable, Rubber, 25'	Cable de alimentación, goma, 25'	
4	9-70M	Torch Head, 125A 70°	Cabezal de la antorcha, 125A 70°	24	57Y01-2	Power Cable, 12.5' 2pc.	Cable de alimentación, 12.5' 2pc.
5	9PM	Torch Head, 125A 180°	Cabezal de la antorcha, 125A 180°	57Y03-2	Power Cable, 25' 2pc.	Cable de alimentación, 25' 2pc.	
6	24-90M	Torch Head, 80A 90°	Cabezal de la antorcha, 80A 90°	25	BS-1	Rubber Switch Boot	Bota del interruptor, de goma
7	24M	Torch Head, 125A 70°	Cabezal de la antorcha, 125A 70°	26	BS-1S	Snap-on Switch Boot	Bota del interruptor, cierre a presión
8	150M	Torch Assembly	Cuerpo de la antorcha	27	SW2-0	On-Off Switch	Interruptor encendido / apagado
9	150VM	Torch Assembly with Valve	Cuerpo de la antorcha con válvula	28	SW1	Switch, Momentary Bulb	Interruptor, bulbo momentáneo
10	150CEM	Flex Element, 150A	Elemento Flex, 150A	SW1F	Switch, Momentary Flat	Interruptor, plano momentáneo	
11	150SEM	Solid Element, 150A	Elemento sólido, 150A	29	150WM	Wrench, 7/16"-1/2"	Llave inglesa, 7/16"-1/2"
12	150VTBM	Torch Body with Valve	Cuerpo de la antorcha con válvula	30	CC-3-10	Cable Cover, 3"X10'	Cobertor del cable, 3"X10'
13	150TBM	Torch Body	Cuerpo de la antorcha	CC-3-22	Cable Cover, 3"X22'	Cobertor del cable, 3"X22'	
14	VS-2	Valve Stem	Vástago de la válvula	31	DA-917F	Dinse 50mm, w/24" Aux. Hose	Dinse 50mm con manguera de 24"
15	41V24	Long Back Cap	Tapa trasera larga	32	DI-917F	Dinse 50mm, in-line	Dinse 50mm de gas en línea
16	41V35	Medium Back Cap	Tapa trasera mediana	33	DP-50M	Dinse 50mm for 2pc. Cable	Dinse 50mm para cable de 2 piezas
17	41V33	Short Back Cap	Tapa trasera corta	34	DA-917FS	Dinse 25mm with 24" Aux. Hose	Dinse 25mm con manguera de 24"
18	57Y02	Long Back Cap	Tapa trasera larga	35	DP-25M	Dinse 25mm for 2pc. Cable	Dinse 25mm para cable de 2 piezas
19	300M	Medium Back Cap	Tapa trasera mediana	36	DI-917FS	Dinse 25mm, in-line	Dinse 25mm de gas en línea
20	57Y04	Short Back Cap	Tapa trasera corta	37	105Z57	Power Cable Adapter	Adaptador de cable de alimentación
21	105Z55R	Ribbed Handle	Empuñadura acanalada				



**BRIGHTON-BEST  
INTERNATIONAL**



# 200M SERIES TIG

## 200 Amp Air-Cooled Torches Torch Packages & Parts Breakdown

# SERIE 200M TIG

## 200 A Antorcha refrigeradas por aire Ensamblajes de antorchas y desglose de piezas

### Available TIG Torches

### Antorchas TIG disponibles

Part#	Description	Descripción	Part#	Description	Descripción
200M	Flex Torch 200 Amp	Antorcha flexible 200 A	200VM	Flex Torch with Valve 200 Amp	Antorcha Flex con válvula 200 A
200M-12-2	Torch Package, 12.5' 2pc.	Ensamblaje de antorcha, 12.5' 2pc.	200VM-12-2	Torch Package, 12.5' 2pc.	Ensamblaje de antorcha, 12.5' 2pc.
200M-12-R	Torch Package, 12.5' 1pc.	Ensamblaje de antorcha, 12.5' 1pc.	200VM-12-R	Torch Package, 12.5' 1pc.	Ensamblaje de antorcha, 12.5' 1pc.
200M-25-2	Torch Package, 25' 2pc.	Ensamblaje de antorcha, 25' 2pc.	200VM-25-2	Torch Package, 25' 2pc.	Ensamblaje de antorcha, 25' 2pc.
200M-25-R	Torch Package, 25' 1pc.	Ensamblaje de antorcha, 25' 1pc.	200VM-25-R	Torch Package, 25' 1pc.	Ensamblaje de antorcha, 25' 1pc.

Torch Package Includes: Torch Body, Flex Element, Solid Element, Power Cable, Handle, 9-70M Head, 1726M Head & Wrench  
El ensamblaje de la antorcha incluye: Cuerpo de la antorcha, elemento Flex, elemento sólido, cable de alimentación, empuñadura, las cabezas 9-70M y 1726M, y llave inglesa



#	Part#	Description	Descripción	#	Part#	Description	Descripción
1	1726M	Torch Head, 150A 70°	Cabezal de la antorcha, 150A 70°	20	57Y04	Short Back Cap	Tapa trasera corta
2	1726PM	Torch Head, 150A 180°	Cabezal de la antorcha, 150A 180°	21	10N15R	Ribbed Handle	Empuñadura acanalada
3	9-90M	Torch Head, 125A 90°	Cabezal de la antorcha, 125A 90°	22	10N15	Smooth Handle	Empuñadura lisa
4	9-70M	Torch Head, 125A 70°	Cabezal de la antorcha, 125A 70°	23	46V28-R	Power Cable, Rubber, 12.5'	Cable de alimentación, goma, 12.5'
5	9PM	Torch Head, 125A 180°	Cabezal de la antorcha, 125A 180°		46V30-R	Power Cable, Rubber, 25'	Cable de alimentación, goma, 25'
6	24-90M	Torch Head, 80A 90°	Cabezal de la antorcha, 80A 90°	24	46V28-2	Power Cable, 12.5' 2pc.	Cable de alimentación, 12.5' 2pc.
7	24M	Torch Head, 80A 70°	Cabezal de la antorcha, 80A 70°		46V30-2	Power Cable, 25' 2pc.	Cable de alimentación, 25' 2pc.
8	200M	Torch Assembly	Cuerpo de la antorcha	25	BL-1	Rubber Switch Boot	Bota del interruptor, de goma
9	200VM	Torch Assembly with Valve	Cuerpo de la antorcha con válvula	26	BL-1S	Snap-on Switch Boot	Bota del interruptor, cierre a presión
10	200CEM	Flex Element, 200A	Elemento flexible, 200A	27	SW2-0	On-Off Switch	Interruptor encendido / apagado
11	200SEM	Solid Element	Elemento sólido, 200A	28	SW1	Switch, Momentary Bulb	Interruptor, bulbo momentáneo
12	200VTBM	Torch Body with Valve	Cuerpo de la antorcha con la válvula		SW1F	Switch, Momentary Flat	Interruptor, plano momentáneo
13	200TBM	Torch Body	Cuerpo de la antorcha	29	200WM	Wrench, 7/16"-1/2"	Llave, 7/16"-1/2"
14	VS-1	Valve Stem	Vástago de la válvula	30	CC-3-10	Cable Cover, 3"X10'	Cobertor del cable, 3"X10'
15	41V24	Long Back Cap	Tapa trasera larga		CC-3-22	Cable Cover, 3"X22'	Cobertor del cable, 3"X22'
16	41V35	Medium Back Cap	Tapa trasera mediana	31	DA-26R	Dinse 50mm, w/Aux. Hose	Dinse 50mm, Manguera auxiliar
17	41V33	Short Back Cap	Tapa trasera corta	32	DP-50M	Dinse 50mm, for 2pc. Cable	Dinse 50mm para cable de 2 piezas
18	57Y02	Long Back Cap	Tapa trasera larga	33	DI-26R	Dinse 50mm, in-line	Dinse 50mm de gas en línea
19	300M	Medium Back Cap	Tapa trasera mediana	34	45V62	Power Cable Adapter	Adaptador de cable de alimentación





**Available TIG Torches**

**Antorchas TIG disponibles**

Part#	Description	Descripción
225M	Flex Torch 225A	Antorcha flexible 225 A
225M-12	Torch Package, Vinyl, 12.5'	Ensamblaje de antorcha, vinilo, 12.5'
225M-12-R	Torch Package, Rubber, 12.5'	Ensamblaje de antorcha, goma, 12.5'
225M-25	Torch Package, Vinyl, 25'	Ensamblaje de antorcha, vinilo, 25'
225M-25-R	Torch Package, Rubber, 25'	Ensamblaje de antorcha, goma, 25'

Torch Package Includes: Torch Body, Power Cable, Water & Gas Hoses, Handle, 9-70M Head & 1726M Head  
El ensamblaje de la antorcha incluye: Cuerpo de la antorcha, cable de alimentación, empuñadura, mangueras de agua y gas, las cabezas 9-70M y 1726M

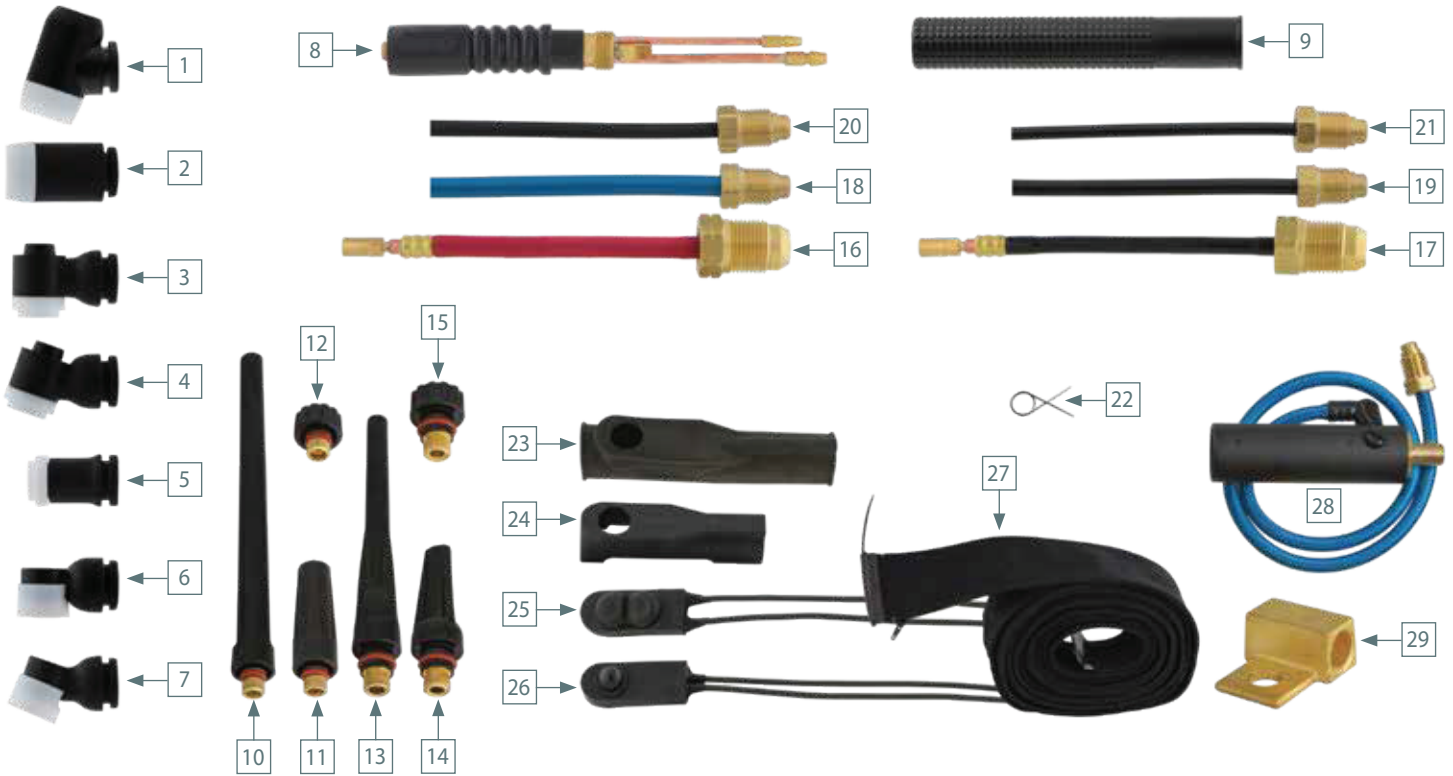

#	Part#	Description	Descripción	#	Part#	Description	Descripción
1	1726M	Torch Head, 150A 70°	Cabezal de la antorcha, 150A 70°	18	45V07R	Water Hose, Rubber, 12.5'	Manguera de agua, goma
2	1726PM	Torch Head, 150A 180°	Cabezal de la antorcha, 150A 180°		45V08R	Water Hose, Rubber, 25'	Manguera de agua, goma, 25'
3	9-90M	Torch Head, 125A 90°	Cabezal de la antorcha, 125A 90°	19	45V07	Water Hose, Vinyl, 12.5'	Manguera de agua, vinilo, 12.5'
4	9-70M	Torch Head, 125A 70°	Cabezal de la antorcha, 125A 70°		45V08	Water Hose, Vinyl, 25'	Manguera de agua, vinilo, 25'
5	9PM	Torch Head, 125A 180°	Cabezal de la antorcha, 125A 180°	20	45V09R	Gas Hose, Rubber, 12.5'	Manguera de gas, goma, 12.5'
6	24-90M	Torch Head, 80A 90°	Cabezal de la antorcha, 80A 90°		45V10R	Gas Hose, Rubber, 25'	Manguera de gas, goma, 25'
7	24M	Torch Head, 80A 70°	Cabezal de la antorcha, 80A 70°	21	45V09	Gas Hose, Vinyl, 12.5'	Manguera de gas, vinilo, 12.5'
8	225M	Flex Torch Body	Cuerpo de la antorcha flexible		45V10	Gas Hose, Vinyl, 25'	Manguera de gas, vinilo, 25'
9	53N06	Smooth Handle	Empuñadura lisa	22	53N04	Hose Clamp	Abrazadera de la manguera
10	41V24	Long Back Cap	Tapa trasera larga	23	BS-1	Rubber Switch Boot	Bota del interruptor, de goma
11	41V35	Medium Back Cap	Tapa trasera mediana	24	BS-1S	Snap-on Switch Boot	Bota del interruptor, cierre a presión
12	41V33	Short Back Cap	Tapa trasera corta	25	SW2-0	On-Off Switch	Interruptor encendido / apagado
13	57Y02	Long Back Cap	Tapa trasera larga	26	SW1	Switch, Momentary Bulb	Interruptor, bulbo momentáneo
14	300M	Medium Back Cap	Tapa trasera mediana		SW1F	Switch, Momentary Flat	Interruptor, plano momentáneo
15	57Y04	Short Back Cap	Tapa trasera corta	27	CC-3-10	Cable Cover, 3"X10'	Cobertor del cable, 3"X10'
16	45V03R	Power Cable, Rubber	Cable de alimentación, Goma, 12.5'		CC-3-22	Cable Cover, 3"X22'	Cobertor del cable, 3"X22'
	45V04R	Power Cable, Rubber	Cable de alimentación, Goma, 25'	28	DA-1820L	Dinse 50mm, w/24" Aux. Hose	Dinse 50mm, Manguera auxiliar de 24"
17	45V03	Power Cable, Vinyl	Cable de alimentación de vinilo, 12.5'	29	45V11	Power Cable Adapter	Adaptador de cable de alimentación
	45V04	Power Cable, Vinyl	Cable de alimentación de vinilo, 25'				



## 125 Amp Air-Cooled Torches Torch Packages & Parts Breakdown

## Antorchas refrigeradas por aire 125 A Ensamblajes de antorchas y desglose de piezas

Available TIG Torches

Antorchas TIG disponibles

Part#	Description	Descripción	Part#	Description	Descripción
9	Air Cooled Torch 125 Amp	Antorcha refrigeradas por aire 125 A	9F	Flex Torch 125 Amp	Antorcha flexible 125 A
9-12-2	Torch Package 12.5' 2pc.	Ensamblaje de antorcha 12.5' 2pc.	9F-12-2	Torch Package 12.5' 2pc.	Ensamblaje de antorcha 12.5' 2pc.
9-12-R	Torch Package 12.5' 1pc.	Ensamblaje de antorcha 12.5' 1pc.	9F-12-R	Torch Package 12.5' 1pc.	Ensamblaje de antorcha 12.5' 1pc.
9-25-2	Torch Package 25' 2pc.	Ensamblaje de antorcha 25' 2pc.	9F-25-2	Torch Package 25' 2pc.	Ensamblaje de antorcha 25' 2pc.
9-25-R	Torch Package 25' 1pc.	Ensamblaje de antorcha 25' 1pc.	9F-25-R	Torch Package 25' 1pc.	Ensamblaje de antorcha 25' 1pc.
9FV	Flex Torch with Valve 125 Amp	Antorcha flexible con válvula 125 A	9V	Torch with Valve 125 Amp	Antorcha con válvula 125 A
9FV-12-2	Torch Package 12.5' 2pc.	Ensamblaje de antorcha 12.5' 2pc.	9V-12-2	Torch Package 12.5' 2pc.	Ensamblaje de antorcha 12.5' 2pc.
9FV-12-R	Torch Package 12.5' 1pc.	Ensamblaje de antorcha 12.5' 1pc.	9V-12-R	Torch Package 12.5' 1pc.	Ensamblaje de antorcha 12.5' 1pc.
9FV-25-2	Torch Package 25' 2pc.	Ensamblaje de antorcha 25' 2pc.	9V-25-2	Torch Package 25' 2pc.	Ensamblaje de antorcha 25' 2pc.
9FV-25-R	Torch Package 25' 1pc.	Ensamblaje de antorcha 25' 1pc.	9V-25-R	Torch Package 25' 1pc.	Ensamblaje de antorcha 25' 1pc.
9P	180° Pencil Torch 125 Amp	Antorcha lápiz 125 A			
9P-12-2	Torch Package 12.5' 2pc.	Ensamblaje de antorcha 12.5' 2pc.	9P-25-2	Torch Package 25' 2pc.	Ensamblaje de antorcha 25' 2pc.
9P-12-R	Torch Package 12.5' 1pc.	Ensamblaje de antorcha 12.5' 1pc.	9P-25-R	Torch Package 25' 1pc.	Ensamblaje de antorcha 25' 1pc.

Torch Package Includes: Torch, Handle, Power Cable, Insulator and Medium Back Cap

El ensamblaje de la antorcha incluye: antorchas, empuñadura, cable de alimentación, aislante y tapa trasera mediana

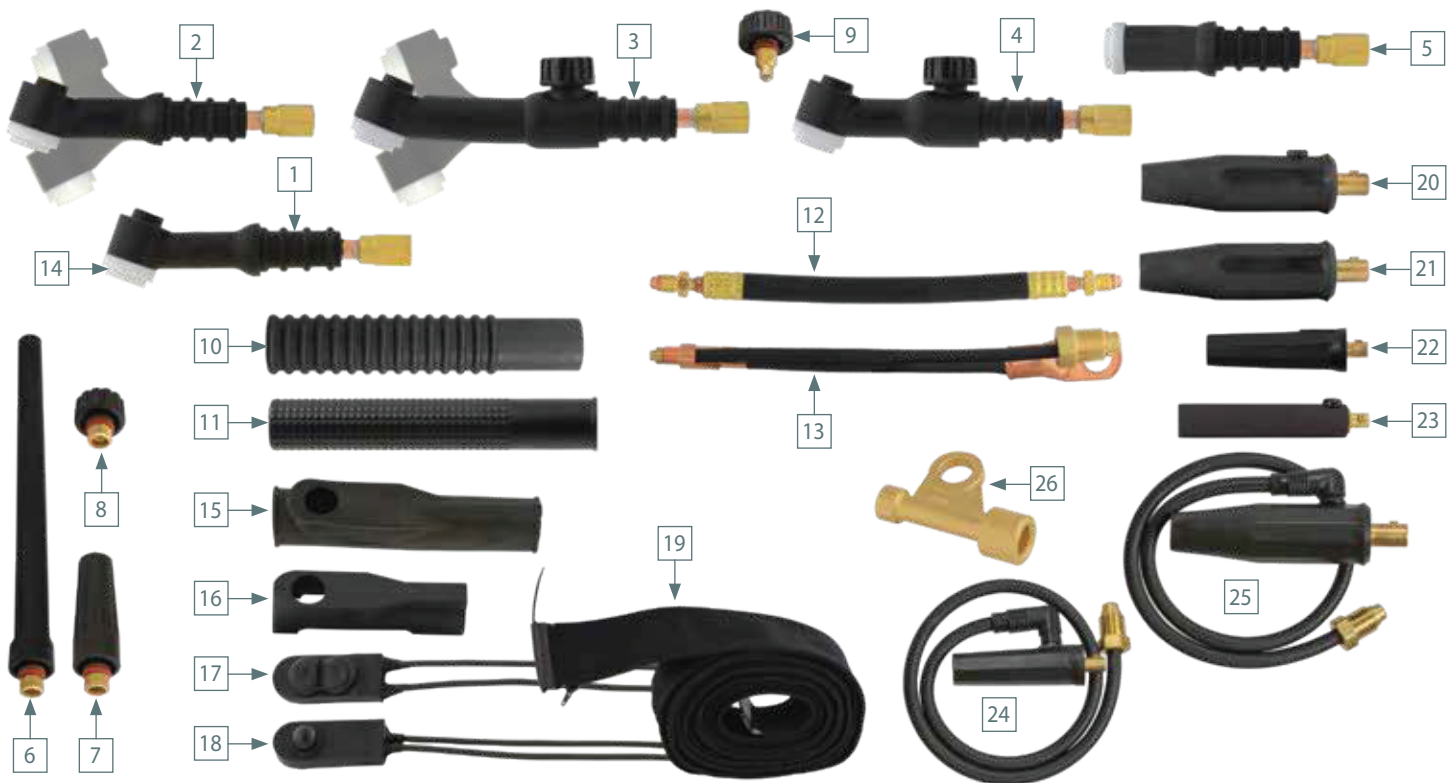

#	Part#	Description	Descripción	#	Part#	Description	Descripción
1	9	Torch Body	Cuerpo de la antorcha	14	598882	Gasket Insulator	Empaque aislador
2	9F	Flex Torch Body	Cuerpo de la antorcha flexible	15	BS-1	Rubber Switch Boot	Bota del interruptor, de goma
3	9FV	Flex Torch Body with Valve	Cuerpo de la antorcha flexible con válvula	16	BS-1S	Snap-on Switch Boot	Bota del interruptor, cierre a presión
4	9V	Torch Body with Valve	Cuerpo de la antorcha con válvula	17	SW2-0	On-Off Switch	Interruptor encendido / apagado
5	9P	Torch Body 180°	Cuerpo de la antorcha 180°	18	SW1	Switch, Momentary Bulb	Interruptor, bulbo momentáneo
6	41V24	Long Back Cap	Tapa trasera larga	18	SW1F	Switch, Momentary Flat	Interruptor, plano momentáneo
7	41V35	Medium Back Cap	Tapa trasera mediana	19	CC-3-10	Cable Cover, 3"X10'	Cobertor del cable, 3"X10'
8	41V33	Short Back Cap	Tapa trasera corta		CC-3-22	Cable Cover, 3"X22'	Cobertor del cable, 3"X22'
9	VS-2	Valve Stem	Vástago de la válvula	20	DI-917F	Dinse 50mm, in-line	Dinse 50mm, De gas en línea
10	H-100R	Ribbed Handle	Empuñadura acanalada	21	DP-50M	Dinse 50mm, for 2pc. Cable	Dinse 50mm para cable de 2 piezas
11	H-100	Smooth Handle	Empuñadura lisa	22	DP-25M	Dinse 25mm, for 2pc. Cable	Dinse 50mm para cable de 2 piezas
12	57Y01R	Power Cable, Rubber, 12.5'	Cable de alimentación, Goma, 12.5'	23	DI-917FS	Dinse 25mm, in-line	Dinse 25mm, De gas en línea
	57Y03R	Power Cable, Rubber, 25'	Cable de alimentación, Goma, 25'	24	DA-917FS	Dinse 25mm, w/Aux. Hose	Dinse 25mm, Manguera auxiliar
13	57Y01-2	Power Cable, 12.5' 2pc.	Cable de alimentación, 12.5' 2pc.	25	DA-917F	Dinse 50mm, w/Aux. Hose	Dinse 50mm, Manguera auxiliar
	57Y03-2	Power Cable, 25' 2pc.	Cable de alimentación, 25' 2pc.	26	105Z57	Power Cable Adapter	Adaptador de cable de alimentación

# 9FMT SERIES TIG

## 125 Amp Air-Cooled Torches Torch Packages & Parts Breakdown

# SERIE 9FMT TIG

## Antorchas refrigeradas por aire 125 A Ensamblajes de antorchas y desglose de piezas

Available TIG Torches

Antorchas TIG disponibles

Part#	Description	Descripción	Part#	Description	Descripción
9FMT	Flex Torch 125 Amp	Antorcha flexible 150 A	9FVMT	Flex Torch with Valve 125Amp	Antorcha flexible con válvula 150 A
9FMT-12-2	Torch Package, 12.5' 2pc.	Ensamblaje de antorcha, 12.5' 2pc.	9FVMT-12-2	Torch Package, 12.5' 2pc.	Ensamblaje de antorcha, 12.5' 2pc.
9FMT-12-R	Torch Package, 12.5' 1pc.	Ensamblaje de antorcha, 12.5' 1pc.	9FVMT-12-R	Torch Package, 12.5' 1pc.	Ensamblaje de antorcha, 12.5' 1pc.
9FMT-25-2	Torch Package, 25' 2pc.	Ensamblaje de antorcha, 25' 2pc.	9FVMT-25-2	Torch Package, 25' 2pc.	Ensamblaje de antorcha, 25' 2pc.
9FMT-25-R	Torch Package, 25' 1pc.	Ensamblaje de antorcha, 25' 1pc.	9FMT-25-R	Torch Package, 25' 1pc.	Ensamblaje de antorcha, 25' 1pc.

Torch Package Includes: Torch, Handle, Power Cable, Insulator and Medium Back Cap  
El ensamblaje de la antorcha incluye: antorchas, empuñadura, cable de alimentación, aislante y tapa trasera mediana



#	Part#	Description	Descripción	#	Part#	Description	Descripción
1	9FM	Torch Head	Cabezal de la antorcha	14	598882	Gasket Insulator	Empaque aislador
2	9FMT	Torch Assembly	Ensamble de la antorcha	15	BS-1	Rubber Switch Boot	Bota del interruptor, de goma
3	9FVMT	Torch Assembly with Valve	Ensamble de antorcha con válvula	16	BS-1S	Snap-on Switch Boot	Bota del interruptor, cierre a presión
4	150VTBM	Torch Body with Valve	Cuerpo de la antorcha con válvula	17	SW2-0	On-Off Switch	Interruptor encendido / apagado
5	150TBM	Torch Body	Cuerpo de la antorcha	18	SW1	Switch, Momentary Bulb	Interruptor, bulbo momentáneo
6	41V24	Long Back Cap	Tapa trasera larga	19	SW1F	Switch, Momentary Flat	Interruptor, plano momentáneo
7	41V35	Medium Back Cap	Tapa trasera mediana	20	CC-3-10	Cable Cover, 3\"X10'	Cobertor del cable, 3\"X10'
8	41V33	Short Back Cap	Tapa trasera corta	21	CC-3-22	Cable Cover, 3\"X22'	Cobertor del cable, 3\"X22'
9	VS-2	Valve Stem	Vástago de la válvula	22	DI-917F	Dinse 50mm, in-line	Dinse 50mm, De gas en línea
10	H-100R	Ribbed Handle	Empuñadura acanalada	23	DP-50M	Dinse 50mm, for 2pc. Cable	Dinse 50mm para cable de 2 piezas
11	H-100	Smooth Handle	Empuñadura lisa	24	DP-25M	Dinse 25mm, for 2pc. Cable	Dinse 25mm para cable de 2 piezas
12	57Y01R	Power Cable, Rubber, 12.5'	Cable de alimentación, Goma, 12.5'	25	DI-917FS	Dinse 25mm, in-line	Dinse 25mm, De gas en línea
13	57Y03R	Power Cable, Rubber, 25'	Cable de alimentación, Goma, 25'	26	DA-917FS	Dinse 25mm, w/ 24\" Aux. Hose	Dinse 25mm, Manguera auxiliar de 24\"
	57Y01-2	Power Cable, 12.5' 2pc.	Cable de alimentación, 12.5' 2pc.		DA-917F	Dinse 50mm, w/24\" Aux. Hose	Dinse 50mm, Manguera auxiliar de 24\"
	57Y03-2	Power Cable, 25' 2pc.	Cable de alimentación, 25' 2pc.		105Z57	Power Cable Adapter	Adaptador de cable de alimentación



**BRIGHTON-BEST  
INTERNATIONAL**



## 150 Amp Air-Cooled Torches Torch Packages & Parts Breakdown

## Antorchas refrigeradas por aire 150 A Ensamblajes de antorchas y desglose de piezas

### Available TIG Torches

### Antorchas TIG disponibles

Part#	Description	Descripción	Part#	Description	Descripción
17	Air Cooled Torch 150 Amp	Antorcha refrigeradas por aire 150 A	17F	Flex Torch 150 Amp	Antorcha flexible 150 A
17-12-2	Torch Package 12.5' 2pc.	Ensamblaje de antorcha 12.5' 2pc.	17F-12-2	Torch Package 12.5' 2pc.	Ensamblaje de antorcha 12.5' 2pc.
17-12-R	Torch Package 12.5' 1pc.	Ensamblaje de antorcha 12.5' 1pc.	17F-12-R	Torch Package 12.5' 1pc.	Ensamblaje de antorcha 12.5' 1pc.
17-25-2	Torch Package 25' 2pc.	Ensamblaje de antorcha 25' 2pc.	17F-25-2	Torch Package 25' 2pc.	Ensamblaje de antorcha 25' 2pc.
17-25-R	Torch Package 25' 1pc.	Ensamblaje de antorcha 25' 1pc.	17F-25-R	Torch Package 25' 1pc.	Ensamblaje de antorcha 25' 1pc.
17FV	Flex Torch with Valve 150 Amp	Antorcha flexible 150 A	17V	Torch with Valve 150 Amp	Antorcha con válvula 150 A
17FV-12-2	Torch Package 12.5' 2pc.	Ensamblaje de antorcha 12.5' 2pc.	17V-12-2	Torch Package 12.5' 2pc.	Ensamblaje de antorcha 12.5' 2pc.
17FV-12-R	Torch Package 12.5' 1pc.	Ensamblaje de antorcha 12.5' 1pc.	17V-12-R	Torch Package 12.5' 1pc.	Ensamblaje de antorcha 12.5' 1pc.
17FV-25-2	Torch Package 25' 2pc.	Ensamblaje de antorcha 25' 2pc.	17V-25-2	Torch Package 25' 2pc.	Ensamblaje de antorcha 25' 2pc.
17FV-25-R	Torch Package 25' 1pc.	Ensamblaje de antorcha 25' 1pc.	17V-25-R	Torch Package 25' 1pc.	Ensamblaje de antorcha 25' 1pc.

Torch Package Includes: Torch, Handle, Power Cable, Insulator and Long Back Cap  
El ensamblaje de la antorcha incluye: antorchas, empuñadura, cable de alimentación, aislante y Tapa trasera larga

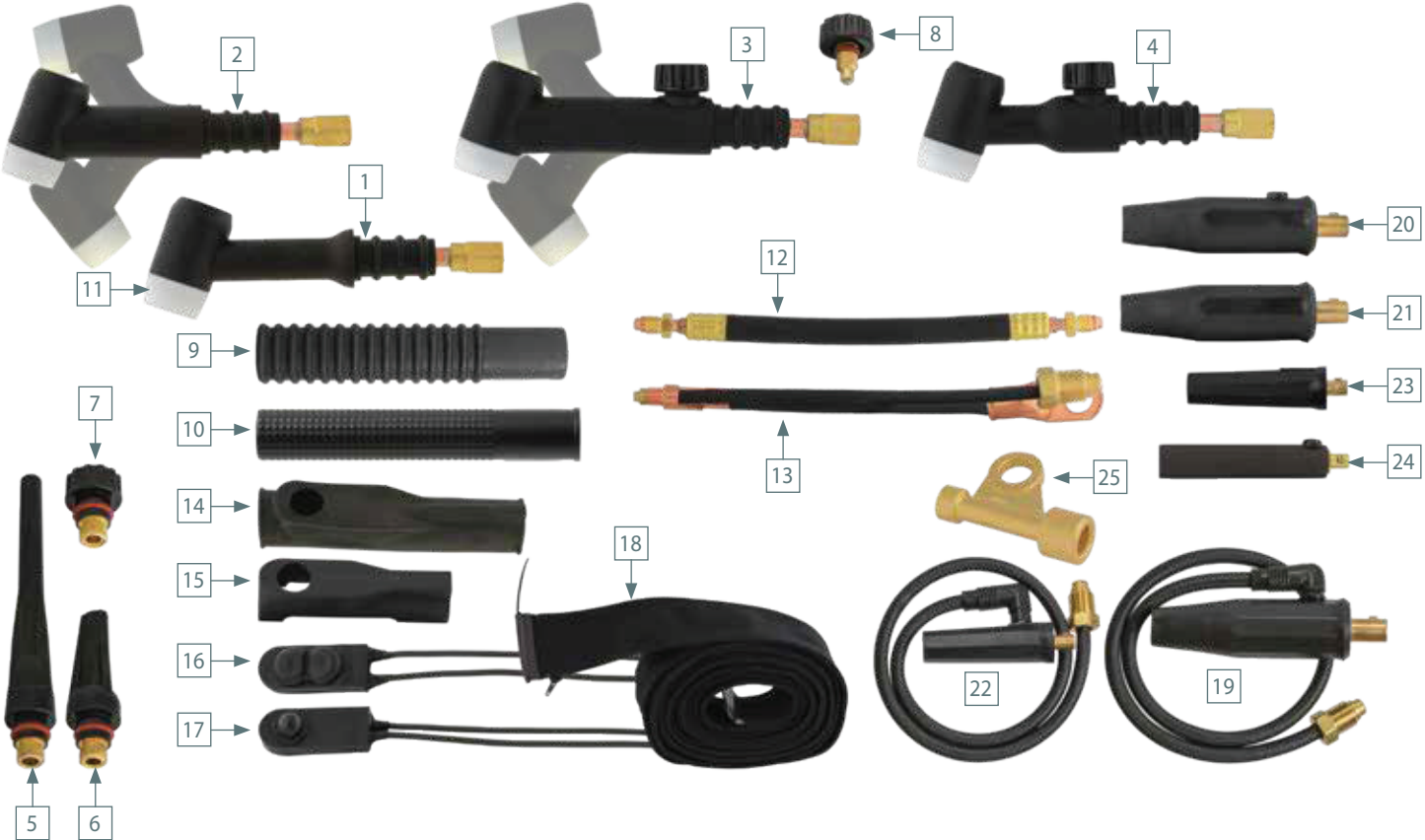

#	Part#	Description	Descripción	#	Part#	Description	Descripción
1	17	Torch Body	Cuerpo de la antorcha	14	BS-1	Rubber Switch Boot	Bota del interruptor, de goma
2	17F	Flex Torch Body	Cuerpo de la antorcha flexible	15	BS-1S	Snap-on Switch Boot	Bota del interruptor, cierre a presión
3	17FV	Flex Torch Body with Valve	Cuerpo de la antorcha flexible con válvula	16	SW2-0	On-Off Switch	Interruptor encendido / apagado
4	17V	Torch Body with Valve	Cuerpo de la antorcha con válvula	17	SW1	Switch, Momentary Bulb	Interruptor, bulbo momentáneo
5	57Y02	Long Back Cap	Tapa trasera larga	18	SW1F	Switch, Momentary Flat	Interruptor, plano momentáneo
6	300M	Medium Back Cap	Tapa trasera mediana	19	CC-3-10	Cable Cover, 3"X10'	Cobertor del cable, 3"X10'
7	57Y04	Short Back Cap	Tapa trasera corta	20	CC-3-22	Cable Cover, 3"X22'	Cobertor del cable, 3"X22'
8	VS-2	Valve Stem	Vástago de la válvula	21	DA-917F	Dinse 50mm, w/24" Aux. Hose	Dinse 50mm, Manguera auxiliar de 24"
9	H-100R	Ribbed Handle	Empuñadura acanalada	22	DI-917F	Dinse 50mm, in-line	Dinse 50mm, De gas en línea
10	H-100	Smooth Handle	Empuñadura lisa	23	DP-50M	Dinse 50mm, for 2pc. Cable	Dinse 50mm para cable de 2 piezas
11	18CG	Gasket Insulator	Empaque aislador	24	DA-917FS	Dinse 25mm, w/ 24" Aux. Hose	Dinse 25mm, Manguera auxiliar de 24"
12	57Y01R	Power Cable, Rubber, 12.5'	Cable de alimentación, Goma, 12.5'	25	DP-25M	Dinse 25mm, for 2pc. Cable	Dinse 25mm para cable de 2 piezas
13	57Y01-2	Power Cable, 12.5' 2pc.	Cable de alimentación, 12.5' 2pc.		DI-917F	Dinse 50mm, in-line	Dinse 50mm, De gas en línea
	57Y03-2	Power Cable, 25' 2pc.	Cable de alimentación, 25' 2pc.		105Z57	Power Cable Adapter	Adaptador de cable de alimentación



# 17FMT SERIES TIG

## 150 Amp Air-Cooled Torches Torch Packages & Parts Breakdown

# SERIE 17FMT TIG

## Antorchas refrigeradas por aire 150 A Ensamblajes de antorchas y desglose de piezas

### Available TIG Torches

### Antorchas TIG disponibles

Part#	Description	Descripción	Part#	Description	Descripción
17FMT	Flex Torch 150 Amp	Antorcha flexible 150 A	17FVMT	Flex Torch with Valve 150 Amp	Antorcha flexible con válvula 150 A
17FMT-12-2	Torch Package, 12.5' 2pc.	Ensamblaje de antorcha, 12.5' 2pc.	17FVMT-12-2	Torch Package, 12.5' 2pc.	Ensamblaje de antorcha, 12.5' 2pc.
17FMT-12-R	Torch Package, 12.5' 1pc.	Ensamblaje de antorcha, 12.5' 1pc.	17FVMT-12-R	Torch Package, 12.5' 1pc.	Ensamblaje de antorcha, 12.5' 1pc.
17FMT-25-2	Torch Package, 25' 2pc.	Ensamblaje de antorcha, 25' 2pc.	17FVMT-25-2	Torch Package, 25' 2pc.	Ensamblaje de antorcha, 25' 2pc.
17FMT-25-R	Torch Package, 25' 1pc.	Ensamblaje de antorcha, 25' 1pc.	17FVMT-25-R	Torch Package, 25' 1pc.	Ensamblaje de antorcha, 25' 1pc.

Torch Package Includes: Torch, Handle, Power Cable, Insulator and Long Back Cap  
El ensamblaje de la antorcha incluye: antorchas, empuñadura, cable de alimentación, aislante y Tapa trasera larga

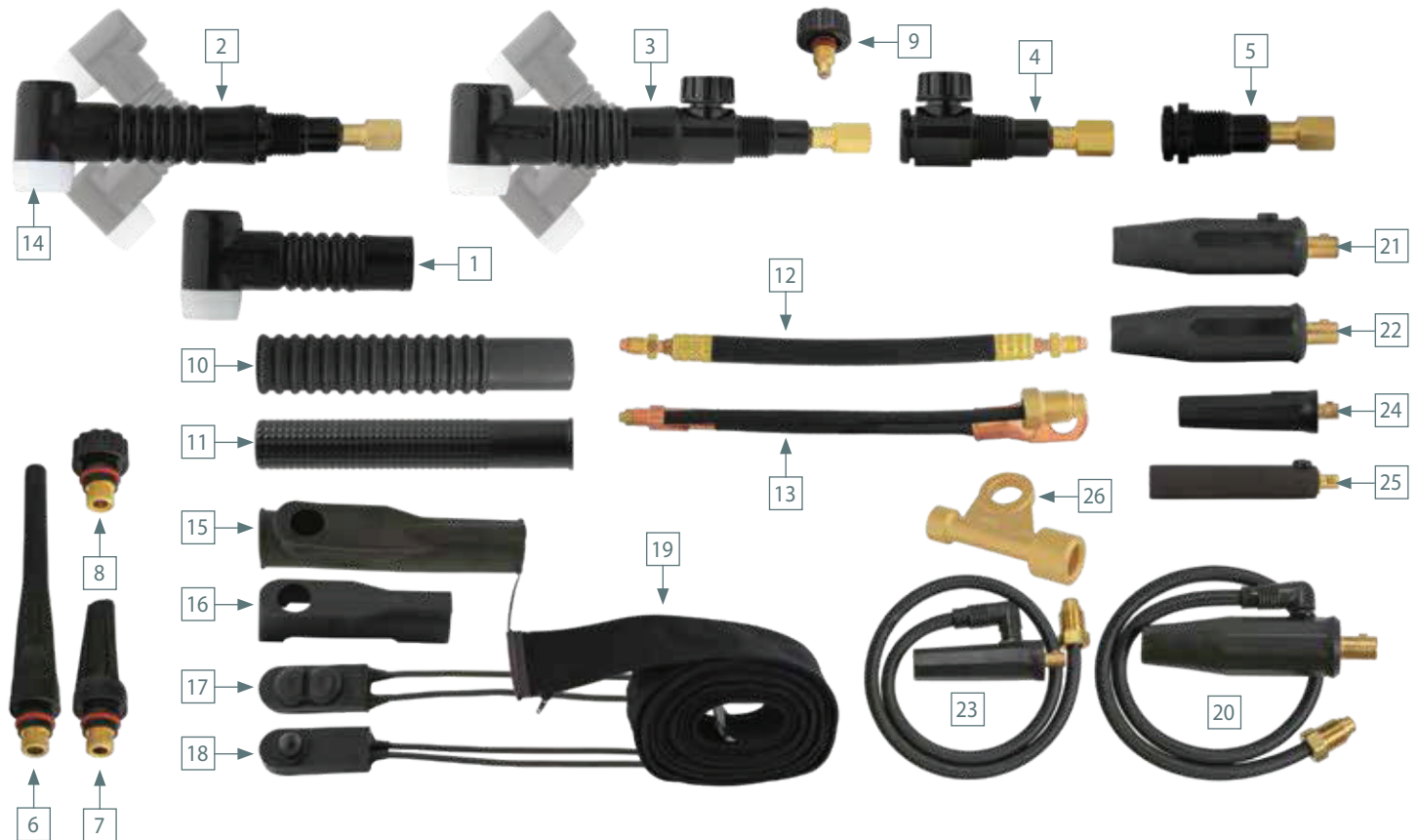

#	Part#	Description	Descripción	#	Part#	Description	Descripción
1	17FM	Torch Head	Cuerpo de la antorcha	14	18CG	Gasket Insulator	Empaque aislador
2	17FMT	Torch Assembly	Assemblaje de la Antorcha	15	BS-1	Rubber Switch Boot	Bota del interruptor, de goma
3	17FVMT	Torch Assembly with Valve	Montaje de antorcha con válvula	16	BS-1S	Snap-on Switch Boot	Bota del interruptor, cierre a presión
4	150VTBM	Flex Torch Body with Valve	Cuerpo de la antorcha flexible con válvula	17	SW2-0	On-Off Switch	Interruptor encendido / apagado
5	150TBM	Torch Body	Cuerpo de la antorcha	18	SW1	Switch, Momentary Bulb	Interruptor, bulbo momentáneo
6	57Y02	Long Back Cap	Tapa trasera larga	18	SW1F	Switch, Momentary Flat	Interruptor, plano momentáneo
7	300M	Medium Back Cap	Tapa trasera mediana	19	CC-3-10	Cable Cover, 3"X10'	Cobertor del cable, 3"X10'
8	57Y04	Short Back Cap	Tapa trasera corta		CC-3-22	Cable Cover, 3"X22'	Cobertor del cable, 3"X22'
9	VS-2	Valve Stem	Vástago de la válvula	20	DA-917F	Dinse 50mm, w/24" Aux. Hose	con manguera de gas auxiliar 24"
10	105Z55R	Ribbed Handle	Empuñadura acanalada	21	DI-917F	Dinse 50mm, in-line	Dinse 50mm, De gas en línea
11	105Z55	Smooth Handle	Empuñadura lisa	22	DP-50M	Dinse 50mm, for 2pc. Cable	Dinse 50mm para cable de 2 piezas
12	57Y01R	Power Cable, Rubber, 12.5'	Cable de alimentación, Goma, 12.5'	23	DA-917FS	Dinse 25mm, w/ 24" Aux. Hose	Dinse 25mm, Manguera auxiliar de 24"
	57Y03R	Power Cable, Rubber, 25'	Cable de alimentación, Goma, 25'	24	DP-25M	Dinse 25mm, for 2pc. Cable	Dinse 25mm para cable de 2 piezas
13	57Y01-2	Power Cable, 12.5' 2pc.	Cable de alimentación, 12.5' 2pc.	25	DI-917FS	Dinse 25mm, in-line	Dinse 25mm, De gas en línea
	57Y03-2	Power Cable, 25' 2pc.	Cable de alimentación, 25' 2pc.	26	105Z57	Power Cable Adapter	Adaptador de cable de alimentación



## 200 Amp Air-Cooled Torches Torch Packages & Parts Breakdown

## Antorchas refrigeradas por aire 200 A Ensamblajes de antorchas y desglose de piezas

### Available TIG Torches

### Antorchas TIG disponibles

Part#	Description	Descripción	Part#	Description	Descripción
26	Air Cooled Torch 200 Amp	Antorcha refrigeradas por aire 200 A	26F	Flex Torch 200 Amp	Antorcha flexible 200 A
26-12-2	Torch Package 12.5' 2pc.	Ensamblaje de antorcha 12.5' 2pc.	26F-12-2	Torch Package 12.5' 2pc.	Ensamblaje de antorcha 12.5' 2pc.
26-12-R	Torch Package 12.5' 1pc.	Ensamblaje de antorcha 12.5' 1pc.	26F-12-R	Torch Package 12.5' 1pc.	Ensamblaje de antorcha 12.5' 1pc.
26-25-2	Torch Package 25' 2pc.	Ensamblaje de antorcha 25' 2pc.	26F-25-2	Torch Package 25' 2pc.	Ensamblaje de antorcha 25' 2pc.
26-25-R	Torch Package 25' 1pc.	Ensamblaje de antorcha 25' 1pc.	26F-25-R	Torch Package 25' 1pc.	Ensamblaje de antorcha 25' 1pc.
26FV	Flex Torch with Valve 200 Amp	Antorcha flexible 200 A	26V	Torch with Valve 200 Amp	Antorcha con válvula 200 A
26FV-12-2	Torch Package 12.5' 2pc.	Ensamblaje de antorcha 12.5' 2pc.	26V-12-2	Torch Package 12.5' 2pc.	Ensamblaje de antorcha 12.5' 2pc.
26FV-12-R	Torch Package 12.5' 1pc.	Ensamblaje de antorcha 12.5' 1pc.	26V-12-R	Torch Package 12.5' 1pc.	Ensamblaje de antorcha 12.5' 1pc.
26FV-25-2	Torch Package 25' 2pc.	Ensamblaje de antorcha 25' 2pc.	26V-25-2	Torch Package 25' 2pc.	Ensamblaje de antorcha 25' 2pc.
26FV-25-R	Torch Package 25' 1pc.	Ensamblaje de antorcha 25' 1pc.	26V-25-R	Torch Package 25' 1pc.	Ensamblaje de antorcha 25' 1pc.

Torch Package Includes: Torch, Handle, Power Cable, Insulator and Long Back Cap  
El ensamblaje de la antorcha incluye: antorchas, empuñadura, cable de alimentación, aislante y Tapa trasera larga



#	Part#	Description	Descripción	#	Part#	Description	Descripción
1	26	Torch Body	Cuerpo de la antorcha	12	VS-1	Valve Stem	Vástago de la válvula
2	26F	Flex Torch Body	Cuerpo de la antorcha flexible	13	18CG	Gasket Insulator	Empaque aislador
3	26FV	Flex Torch Body with Valve	Cuerpo de la antorcha flexible con válvula	14	BL-1	Rubber Switch Boot	Bota del interruptor, de goma
4	26V	Torch Body with Valve	Cuerpo de la antorcha con válvula	15	BL-1S	Snap-on Switch Boot	Bota del interruptor, cierre a presión
5	57Y02	Long Back Cap	Tapa trasera larga	16	SW2-0	On-Off Switch	Interruptor encendido / apagado
6	300M	Medium Back Cap	Tapa trasera mediana	17	SW1	Switch, Momentary Bulb	Interruptor, bulbo momentáneo
7	57Y04	Short Back Cap	Tapa trasera corta		SW1F	Switch, Momentary Flat	Interruptor, plano momentáneo
8	H-200R	Ribbed Handle	Empuñadura acanalada	18	CC-3-10	Cable Cover, 3"X10'	Cobertor del cable, 3"X10'
9	H-200	Smooth Handle	Empuñadura lisa		CC-3-22	Cable Cover, 3"X22'	Cobertor del cable, 3"X22'
10	46V28-R	Power Cable, Rubber, 12.5'	Cable de alimentación, goma, 12.5'	19	DA-26R	Dinse 50mm, w/24" Aux. Hose	Dinse 50mm, Manguera auxiliar de 24"
	46V30-R	Power Cable, Rubber, 25'	Cable de alimentación, Goma, 25'	20	DI-26R	Dinse 50mm, in-line	Dinse 50mm de gas en línea
11	46V28-2	Power Cable, 12.5' 2pc.	Cable de alimentación, 12.5' 2pc.	21	DP-50M	Dinse 50mm, for 2pc. Cable	Dinse 50mm para cable de 2 piezas
	46V30-2	Power Cable, 25' 2pc.	Cable de alimentación, 25' 2pc.	22	45V62	Power Cable Adapter	Adaptador de cable de alimentación

# 26FMT SERIES TIG

## 200 Amp Air-Cooled Torches Torch Packages & Parts Breakdown

# SERIE 26FMT TIG

## Antorchas refrigeradas por aire 200 A Ensamblajes de antorchas y desglose de piezas

### Available TIG Torches

### Antorchas TIG disponibles

Part#	Description	Descripción	Part#	Description	Descripción
26FMT	Flex Torch 200 Amp	Antorcha flexible 200 A	26FVMT	Flex Torch with Valve 200 Amp	Antorcha flexible con válvula 200 A
26FMT-12-2	Torch Package, 12.5' 2pc.	Ensamblaje de antorcha, 12.5' 2pc.	26FVMT-12-2	Torch Package, 12.5' 2pc.	Ensamblaje de antorcha, 12.5' 2pc.
26FMT-12-R	Torch Package, 12.5' 1pc.	Ensamblaje de antorcha, 12.5' 1pc.	26FVMT-12-R	Torch Package, 12.5' 1pc.	Ensamblaje de antorcha, 12.5' 1pc.
26FMT-25-2	Torch Package, 25' 2pc.	Ensamblaje de antorcha, 25' 2pc.	26FVMT-25-2	Torch Package, 25' 1pc.	Ensamblaje de antorcha, 25' 2pc.
26FMT-25-R	Torch Package, 25' 1pc.	Ensamblaje de antorcha, 25' 1pc.	26FVMT-25-R	Torch Package, 25' 1pc.	Ensamblaje de antorcha, 25' 1pc.

Torch Package Includes: Torch, Handle, Power Cable, Insulator and Long Back Cap  
El ensamblaje de la antorcha incluye: antorchas, empuñadura, cable de alimentación, aislante y Tapa trasera larga



#	Part#	Description	Descripción	#	Part#	Description	Descripción
1	26FM	Torch Head	Cabezal de la antorcha	13	VS-1	Valve Stem	Vástago de la válvula
2	26FMT	Torch Assembly	Assemblaje de la Antorcha	14	18CG	Gasket Insulator	Empaque aislador
3	26FVMT	Torch Assembly with Valve	Montaje de antorcha con válvula	15	BL-1	Rubber Switch Boot	Bota del interruptor, de goma
4	200VTBM	Flex Torch Body with Valve	Cuerpo de la antorcha flexible con válvula	16	BL-1S	Snap-on Switch Boot	Bota del interruptor, cierre a presión
5	200TBM	Flex Torch Body	Cuerpo de la antorcha flexible	17	SW2-0	On-Off Switch	Interruptor encendido / apagado
6	57Y02	Long Back Cap	Tapa trasera larga	18	SW1	Switch, Momentary Bulb	Interruptor, bulbo momentáneo
7	300M	Medium Back Cap	Tapa trasera mediana		SW1F	Switch, Momentary Flat	Interruptor, plano momentáneo
8	57Y04	Short Back Cap	Tapa trasera corta	19	CC-3-10	Cable Cover, 3"X10'	Cobertor del cable, 3"X10'
9	10N15R	Ribbed Handle	Empuñadura acanalada		CC-3-22	Cable Cover, 3"X22'	Cobertor del cable, 3"X22'
10	10N15	Smooth Handle	Empuñadura lisa	20	DA-26R	Dinse 50mm, w/24" Aux. Hose	Dinse 50mm, Manguera auxiliar de 24"
11	46V28-R	Power Cable, Rubber, 12.5'	Cable de alimentación, Goma, 12.5'	21	DI-26R	Dinse 50mm, in-line	Dinse 50mm de gas en línea
	46V30-R	Power Cable, Rubber, 25'	Cable de alimentación, Goma, 25'	22	DP-50M	Dinse 50mm, for 2pc. Cable	Dinse 50mm para cable de 2 piezas
12	46V28-2	Power Cable, 12.5' 2pc.	Cable de alimentación, 12.5' 2pc.	23	45V62	Power Cable Adapter	Adaptador de cable de alimentación
	46V30-2	Power Cable, 25' 2pc.	Cable de alimentación, 25' 2pc.				

## 80 Amp Air-Cooled Torches Torch Packages & Parts Breakdown

## Antorchas refrigeradas por aire 80 A Ensamblajes de antorchas y desglose de piezas

### Available TIG Torches

### Antorchas TIG disponibles

Part#	Description	Descripción	Part#	Description	Descripción
24	Air Cooled Torch 80 Amp, 60°	Antorcha refrigeradas por aire 80 A, 60°	24N	Air Cooled Torch 80 Amp 90°	Antorcha refrigeradas por aire 80 A, 90°
24-12-R	Torch Package 12.5' 1pc.	Ensamblaje de antorcha 12.5' 1pc.	24N-12-R	Torch Package 12.5' 1pc.	Ensamblaje de antorcha 12.5' 1pc.
24-25-R	Torch Package 25' 1pc.	Ensamblaje de antorcha 25' 1pc.	24N-25-R	Torch Package 25' 1pc.	Ensamblaje de antorcha 25' 1pc.
24V	Torch with Valve 80 Amp, 60°	Antorcha con válvula 80 A, 60°	24VN	Torch with Valve 80 Amp, 90°	Antorcha con válvula 80 A, 90°
24V-12-R	Torch Package 12.5' 1pc.	Ensamblaje de antorcha 12.5' 1pc.	24VN-12-R	Torch Package 12.5' 1pc.	Ensamblaje de antorcha 12.5' 1pc.
24V-25-R	Torch Package 25' 1pc.	Ensamblaje de antorcha 25' 1pc.	24VN-25-R	Torch Package 25' 1pc.	Ensamblaje de antorcha 25' 1pc.

Torch Package Includes: Torch, Handle, Power Cable, and Insulator  
El ensamblaje de la antorcha incluye: : antorchas, empuñadura, cable de alimentación, aislador

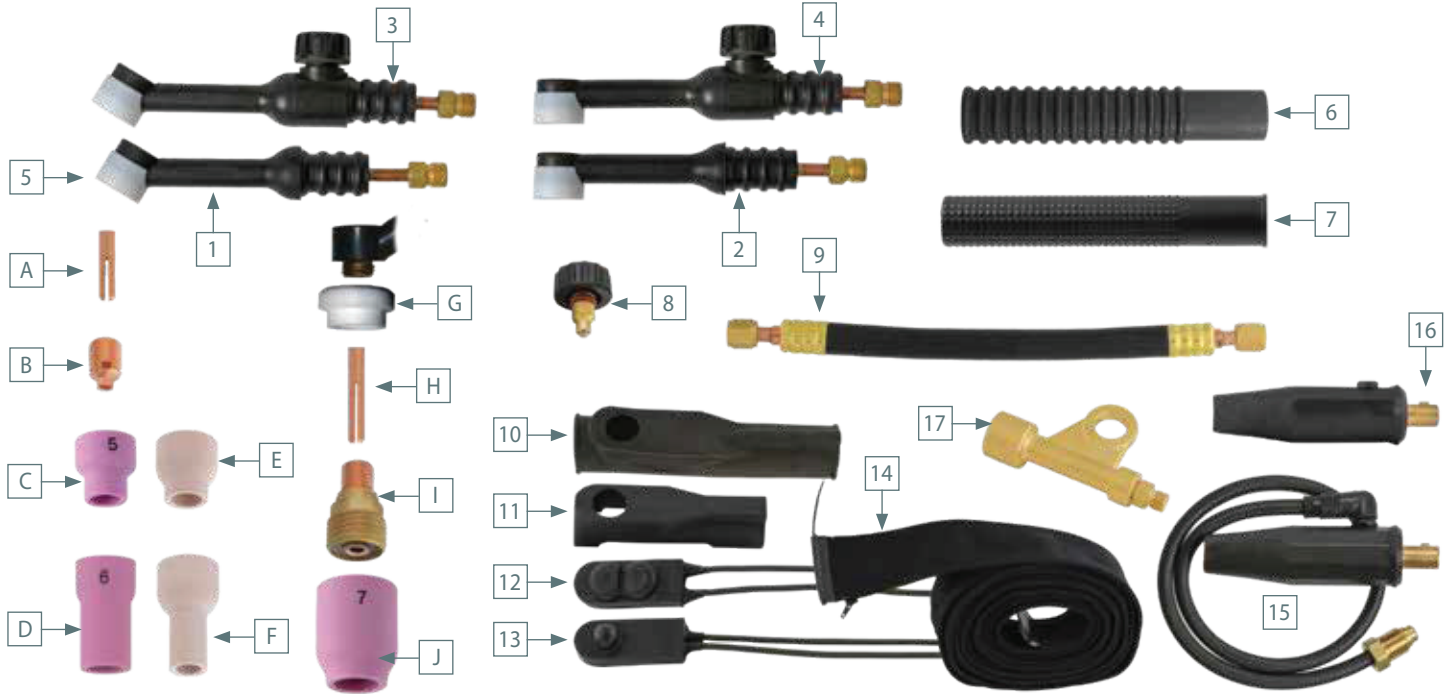

#	Part#	Description	Descripción	#	Part#	Description	Descripción
1	24	Torch Body 60°	Cuerpo de la antorcha 60°	10	BS-1	Rubber Switch Boot	Bota del interruptor, de goma
2	24N	Torch Body 90°	Cuerpo de la antorcha 90°	11	BS-1S	Snap-on Switch Boot	Bota del interruptor, cierre a presión
3	24V	Torch Body with Valve 60°	Cuerpo de la antorcha con válvula 60°	12	SW2-0	On-Off Switch	Interruptor encendido / apagado
4	24VN	Torch Body with Valve 90°	Cuerpo de la antorcha con válvula 90°	13	SW1	Switch, Momentary Bulb	Interruptor, bulbo momentáneo
5	53N22	Gasket Insulator	Empaque aislador	SW1F	Switch, Momentary Flat	Interruptor, plano momentáneo	
6	H-100R	Ribbed Handle	Empuñadura acanalada	14	CC-3-10	Cable Cover, 3"X10'	Cobertor del cable, 3"X10'
7	H-100	Smooth Handle	Empuñadura lisa	CC-3-22	Cable Cover, 3"X22'	Cobertor del cable, 3"X22'	
8	VS-2	Valve Stem	Vástago de la válvula	15	DA-24F	Dinse 50mm, w/24" Aux. Hose	Dinse 50mm, Manguera auxiliar de 24"
9	56Y38R	Power Cable, Rubber, 12.5'	Cable de alimentación, goma, 12.5'	16	DI-24F	Dinse 50mm, in-line	Dinse 50mm de gas en línea
	57Y97R	Power Cable, Rubber, 25'	Cable de alimentación, Goma, 25'	17	53N43	Power Cable Adapter	Adaptador de cable de alimentación

Description	Descripción	Electrode Diameter Diámetro del electrodo						
		.020" (0.5mm)	.040" (1.0mm)	1/16" (1.6mm)	3/32" (2.4mm)			
		Nozzle Size	Tamaño de la boquilla	#4 (1/4")	#5 (5/16")	#6 (3/8")	#7 (7/16")	#8 (1/2")
Standard Set-up / Configuración estándar								
A	Collet	Mordaza		53N15	53N16	53N14	24C332	
B	Collet Body	Portamordaza		53N17	53N18	53N19	24CB332	
C	Alumina Nozzle Standard	Boquilla estándar de alumina	53N23A	53N24A	53N25A	53N27A		
D	Alumina Nozzle Long	Boquilla larga de alumina				53N26A		
E	Lava Nozzle Standard	Boquilla estándar de lava	53N23	53N24	53N25	53N27		
F	Lava Nozzle Long	Boquilla larga de lava		53N28		53N26		
Gas Lens Set-up / Configuración de gas lens								
G	Gasket Insulator	Empaque aislador		53N66	53N66	53N66	53N66	53N66
H	Collet	Coronilla		53N62	53N63	53N64	24GLC332	
I	Gas Lens Collet Body	Portamordaza, gas lens		45V41	45V42	45V43	45V44	
J	Alumina Nozzle Standard	Boquilla estándar de alumina		53N58	53N59	53N60	53N61	53N61S



# 24FMT SERIES TIG

## 80 Amp Air-Cooled Torches Torch Packages & Parts Breakdown

# SERIE 24FMT TIG

## Antorchas refrigeradas por aire 80 A Ensamblajes de antorchas y desglose de piezas

### Available TIG Torches

### Antorchas TIG disponibles

Part#	Description	Descripción	Part#	Description	Descripción
24FMT	Flex Torch 80 Amp	Antorcha flexible 80 A	24FVMT	Flex Torch with Valve 80 Amp	Antorcha flexible con válvula 80 A
24FMT-12-2	Torch Package, 12.5' 2pc.	Ensamblaje de antorcha, 12.5' 2pc.	24FVMT-12-2	Torch Package, 12.5' 2pc.	Ensamblaje de antorcha, 12.5' 2pc.
24FMT-12-R	Torch Package, 12.5' 1pc.	Ensamblaje de antorcha, 12.5' 1pc.	24FVMT-12-R	Torch Package, 12.5' 1pc.	Ensamblaje de antorcha, 12.5' 1pc.
24FMT-25-2	Torch Package, 25' 2pc.	Ensamblaje de antorcha, 25' 2pc.	24FVMT-25-2	Torch Package, 25' 2pc.	Ensamblaje de antorcha, 25' 2pc.
24FMT-25-R	Torch Package, 25' 1pc.	Ensamblaje de antorcha, 25' 1pc.	24FVMT-25-R	Torch Package, 25' 1pc.	Ensamblaje de antorcha, 25' 1pc.

Torch Package Includes: Torch, Handle, Power Cable, Insulator  
El ensamblaje de la antorcha incluye: antorchas, empuñadura, cable de alimentación, aislador

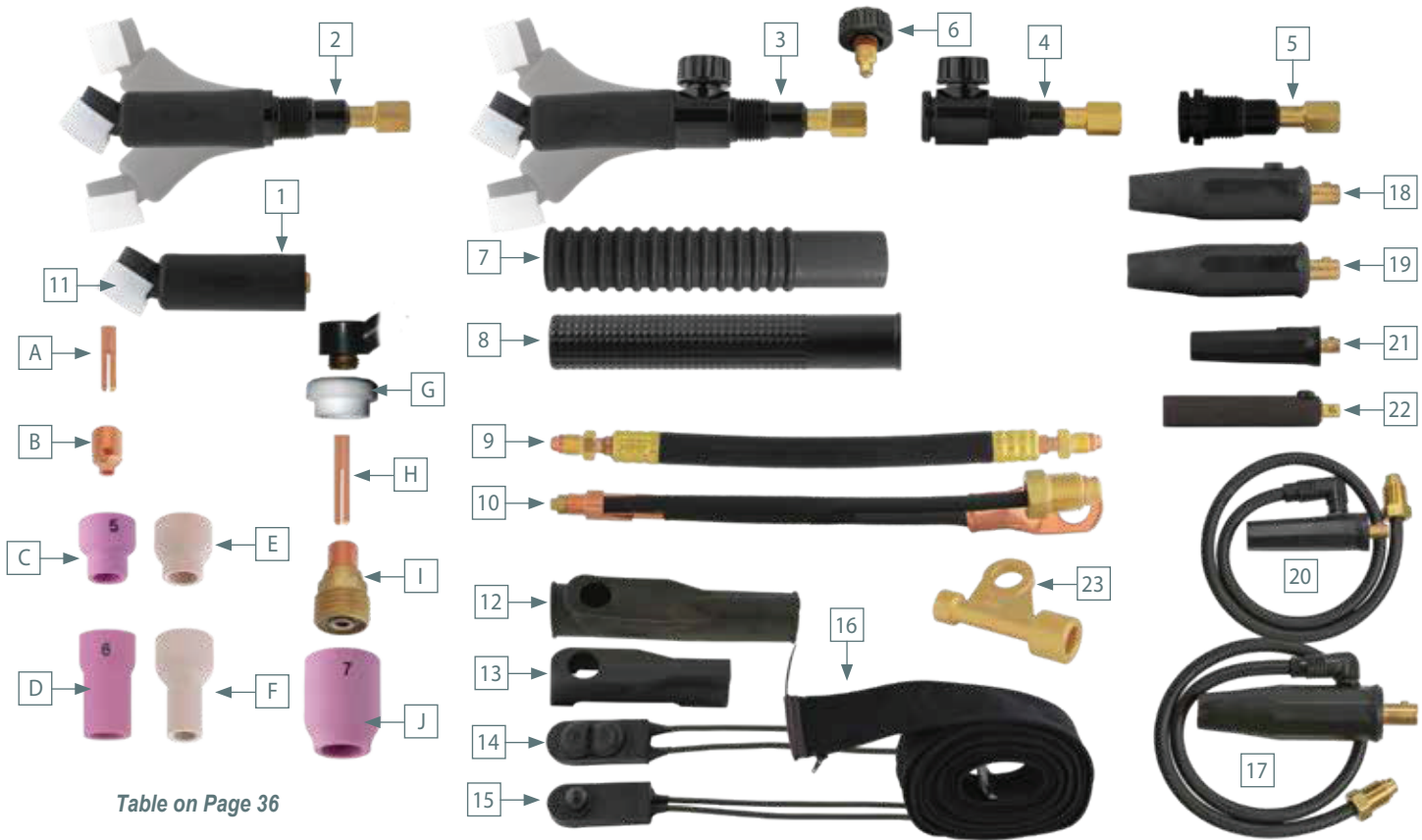

Table on Page 36

#	Part#	Description	Descripción	#	Part#	Description	Descripción	
1	24FM	Torch Head	Cabezal de la antorcha	13	BS-1S	Snap-on Switch Boot	Bota del interruptor, cierre a presión	
2	24FMT	Torch Assembly	Assemblaje de la Antorcha	14	SW2-0	On-Off Switch	Interruptor encendido / apagado	
3	24FVMT	Torch Assembly with Valve	Montaje de antorcha con válvula	15	SW1	Switch, Momentary Bulb	Interruptor, bulbo momentáneo	
4	150VTBM	Flex Torch Body with Valve	Cuerpo de la antorcha flexible con válvula	16	SW1F	Switch, Momentary Flat	Interruptor, plano momentáneo	
5	150TBM	Torch Body	Cuerpo de la antorcha	17	CC-3-10	Cable Cover, 3"X10'	Cobertor del cable, 3"X10'	
6	VS-2	Valve Stem	Vástago de la válvula	18	CC-3-22	Cable Cover, 3"X22'	Cobertor del cable, 3"X22'	
7	105Z55R	Ribbed Handle	Empuñadura acanalada	19	DA-917F	Dinse 50mm, w/24" Aux. Hose	Dinse 50mm, Manguera auxiliar de 24"	
8	105Z55	Smooth Handle	Empuñadura lisa	20	DI-917F	Dinse 50mm, in-line	Dinse 50mm, De gas en línea	
9	57Y01R	Power Cable, Rubber, 12.5'	Cable de alimentación, Goma, 12.5'	21	DP-50M	Dinse 50mm, for 2pc. Cable	Dinse 50mm para cable de 2 piezas	
10	57Y03R	Power Cable, Rubber, 25'	Cable de alimentación, Goma, 25'	22	DA-917FS	Dinse 25mm, w/ 24" Aux. Hose	Dinse 25mm, Manguera auxiliar de 24"	
11	57Y01-2	Power Cable, 12.5' 2pc.	Cable de alimentación, 12.5' 2pc.	23	DP-25M	Dinse 25mm, for 2pc. Cable	Dinse 25mm para cable de 2 piezas	
12	57Y03-2	Power Cable, 25' 2pc.	Cable de alimentación, 25' 2pc.	24	DI-917FS	Dinse 25mm, in-line	Dinse 25mm, De gas en línea	
	11	53N22	Gasket Insulator		25	105Z57	Power Cable Adapter	Adaptador de cable de alimentación
	12	BS-1	Rubber Switch Boot					

# 24W SERIES TIG

## 180 Amp Water-Cooled Torches Torch Packages & Parts Breakdown

# SERIE 24W TIG

## Antorchas refrigeradas por agua 180 A Ensamblajes de antorchas y desglose de piezas

### Available TIG Torches

### Antorchas TIG disponibles

Part#	Description	Descripción	Part#	Description	Descripción
24W	Water Cooled Torch 180 Amp 60°	Antorcha refrigeradas por agua 180A	24WN	Water Cooled Torch 180 Amp 90°	Antorcha refrigeradas por aire 180 A
24W-12	Torch Package, Vinyl, 12.5'	Ensamblaje de antorcha, vinilo, 12.5'	24WN-12	Torch Package, Vinyl, 12.5'	Ensamblaje de antorcha, vinilo, 12.5'
24W-12-R	Torch Package, Rubber, 12.5'	Ensamblaje de antorcha, goma, 12.5'	24WN-12-R	Torch Package, Rubber, 12.5'	Ensamblaje de antorcha, goma, 12.5'
24W-25	Torch Package, Vinyl, 25'	Ensamblaje de antorcha, vinilo, 25'	24WN-25	Torch Package, Vinyl, 25'	Ensamblaje de antorcha, vinilo, 25'
24W-25-R	Torch Package, Rubber, 25'	Ensamblaje de antorcha, goma, 25'	24WN-25-R	Torch Package, Rubber, 25'	Ensamblaje de antorcha, goma, 25'

Torch Package Includes: Torch Body, Handle, Power Cable, Water & Gas Hoses and insulator  
El ensamblaje de la antorcha incluye: Cuerpo de la antorcha, Empuñadura, cable de alimentación, mangueras de agua y gas, aislador

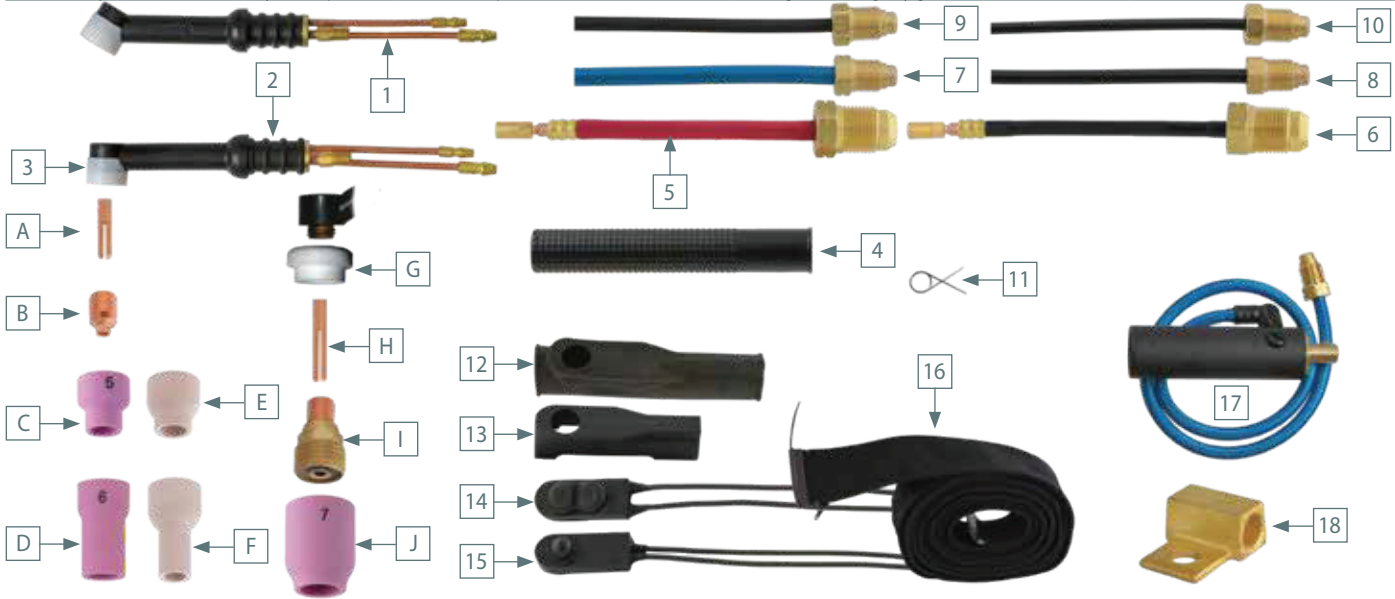

#	Part#	Description	Descripción	#	Part#	Description	Descripción
1	24W	Torch Body60°	Cuerpo de la antorcha	10	45V09	Gas Hose, Vinyl, 12.5'	Maguera de gas, vinilo, 12.5'
2	24WN	Torch Body90°	Cuerpo de la antorcha flexible	45V10	Gas Hose, Vinyl, 25'	Maguera de gas, vinilo, 25'	
3	53N22	Gasket Insulator	Empaque aislador	11	53N04	Hose Clamp	Abrazadera de la manguera
4	H-100	Handle	Empuñadura	12	BS-1	Rubber Switch Boot	Bota del interruptor, de goma
5	45V03R	Power Cable, Rubber	Cable de alimentación, Goma, 12.5'	13	BS-1S	Snap-on Switch Boot	Bota del interruptor, cierre a presión
6	45V04R	Power Cable, Rubber	Cable de alimentación, Goma, 25'	14	SW2-0	On-Off Switch	Interruptor encendido / apagado
7	45V03	Power Cable, Vinyl	Cable de alimentación de vinilo, 12.5'	15	SW1	Switch, Momentary Bulb	Interruptor, bulbo momentáneo
8	45V04	Power Cable, Vinyl	Cable de alimentación de vinilo, 25'	15	SW1F	Switch, Momentary Flat	Interruptor, plano momentáneo
9	45V07R	Water Hose, Rubber, 12.5'	Manguera de agua, goma, 12.5'	16	CC-3-10	Cable Cover, 3"X10'	Cobertor del cable, 3"X10'
10	45V08R	Water Hose, Rubber, 25'	Manguera de agua, goma, 25'	16	CC-3-22	Cable Cover, 3"X22'	Cobertor del cable, 3"X22'
11	45V07	Water Hose, Vinyl, 12.5'	Manguera de agua, vinilo, 12.5'	17	DA-1820L	Dinse 50mm, w/24" Aux. Hose	Dinse 50mm, Manguera auxiliar de 24"
12	45V08	Water Hose, Vinyl, 25'	Manguera de agua, vinilo, 25'	18	45V11	Power Cable Adapter	Adaptador para cable de alimentación
13	45V09R	Gas Hose, Rubber, 12.5'	Manquera de gas, goma, 12.5'				
14	45V10R	Gas Hose, Rubber, 25'	Manquera de gas, goma, 25'				

Description	Descripción	Electrode Diameter Diámetro del electrodo					
		.020" (0.5mm)	.040" (1.0mm)	1/16" (1.6mm)	3/32" (2.4mm)		
		Nozzle Size Tamaño de la boquilla	#4 (1/4")	#5 (5/16")	#6 (3/8")	#7 (7/16")	#8 (1/2")
Standard Set-up / Configuración estándar							
A	Collet	Mordaza	53N15	53N16	53N14	24C332	
B	Collet Body	Portamordaza	53N17	53N18	53N19	24CB332	
C	Alumina Nozzle Standard	Boquilla estándar de alumina	53N23A	53N24A	53N25A	53N27A	
D	Alumina Nozzle Long	Boquilla larga de alumina				53N26A	
E	Lava Nozzle Standard	Boquilla estándar de lava	53N23	53N24	53N25	53N27	
F	Lava Nozzle Long	Boquilla larga de lava	53N28			53N26	
Gas Lens Set-up / Configuración de gas lens							
G	Gasket Insulator	Empaque aislador	53N66	53N66	53N66	53N66	53N66
H	Collet	Mordaza	53N62	53N63	53N64	24GLC332	
I	Gas Lens Collet Body	Portamordaza, gas lens	45V41	45V42	45V43	45V44	
J	Alumina Nozzle Standard	Boquilla estándar de alumina	53N58	53N59	53N60	53N61	53N61S

## 250 Amp Water-Cooled Torches Torch Packages & Parts Breakdown

## Antorchas refrigeradas por agua 250 A Ensamblajes de antorchas y desglose de piezas

### Available TIG Torches

### Antorchas TIG disponibles

Part#	Description	Descripción	Part#	Description	Descripción
22A	Water Cooled Torch 250 Amp 180°	Antorcha refrigeradas por agua 250 A	22B	Water Cooled Torch 250 Amp 180°	Antorcha refrigeradas por agua 250 A
22A-12-R	Torch Package, Rubber, 12.5'	Ensamblaje de antorcha, goma, 12.5'	22B-12-R	Torch Package, Rubber, 12.5'	Ensamblaje de antorcha, goma, 12.5'
22A-25-R	Torch Package, Rubber, 25'	Ensamblaje de antorcha, goma, 25'	22B-25-R	Torch Package, Rubber, 25'	Ensamblaje de antorcha, goma, 25'

Torch Package Includes: Torch Body, Power Cable, Water & Gas Hoses, and insulator  
El ensamblaje de la antorcha incluye: Cuerpo de la antorcha, cable de alimentación, mangueras de agua y gas, aislador

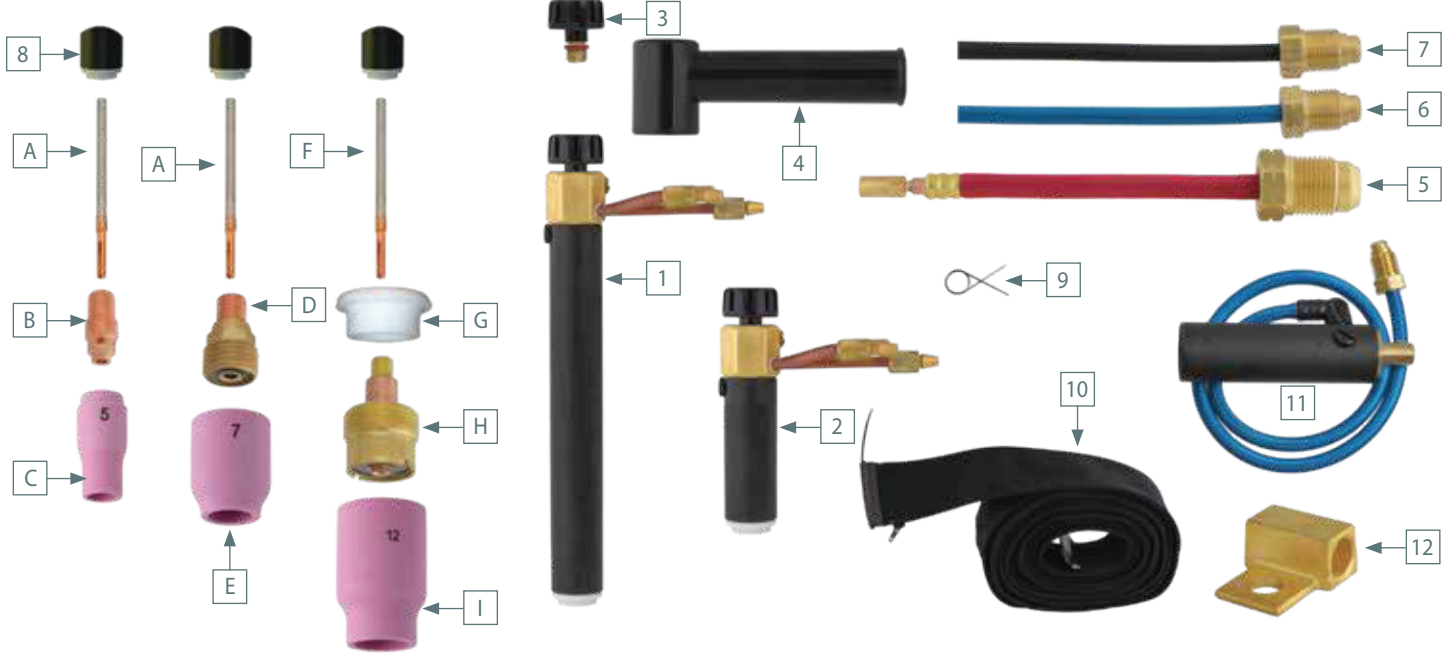

#	Part#	Description	Descripción	#	Part#	Description	Descripción
1	22A	Machine Torch 7"	Antorcha para uso maquinado 7"	7	45V09R	Gas Hose, Rubber, 12.5'	Manquera de gas, goma, 12.5'
2	22B	Machine Torch 3"	Antorcha para uso maquinado 3"	8	45V10R	Gas Hose, Rubber, 25'	Manquera de gas, goma, 25'
3	22-7	Collet Knob	Botón de la mordaza	9	53N04	Hose Clamp	Abrazadera de la manguera
4	22-9	Insulating Boot	Bota aislante	10	CC-3-10	Cable Cover, 3"X10'	Cobertor del cable, 3"X10'
5	45V03R	Power Cable, Rubber, 12.5'	Cable de alimentación, goma, 12.5'		CC-3-22	Cable Cover, 3"X22'	Cobertor del cable, 3"X22'
6	45V04R	Power Cable, Rubber, 25'	Cable de alimentación, goma, 25'	11	DA-1820L	Dinse 50mm, w/24" Aux. Hose	Dinse 50mm, Manquera auxiliar de 24"
	45V07RM	Water Hose, Rubber, 12.5'	Manguera de agua, goma, 12.5'	12	45V11	Power Cable Adapter	Adaptador para cable de alimentación
	45V08RM	Water Hose, Rubber, 25'	Manguera de agua, goma, 25'				

Description	Descripción	Electrode Diameter Diametro del electrodo	Nozzle Size / Tamaño de la boquilla					
			#4 (1/4 ")	#5 (5/16 ")	#6 (3/8 ")	#7 (7/16 ")	#8 (1/2 ")	#10 (5/8 ")
Standard Set-up / Configuración estándar								
8	Gasket Insulator	Empaque aislador		22-10	22-10	22-10	22-10	22-10
A	22A Collet	Mordaza 22A			22N22A	22N23A	22N24A	
	22B Collet	Mordaza 22B			22N22B	22N23B	22N24B	
B	Collet Body	Portamordaza		13N26	13N27	13N28	13N29	
C	Alumina Nozzle Standard	Boquilla estándar de alumina	13N08	13N09	13N10	13N11	13N12	13N13
Gas Lens Set-up / Configuración de gas lens								
A	22A Collet	Mordaza 22A			22N22A	22N23A	22N24A	
	22B Collet	Mordaza 22B			22N22B	22N23B	22N24B	
D	Gas Lens Collet Body	Portamordaza gas lens		45V42	45V43	45V44	45V45	
E	Alumina Nozzle Standard	Boquilla estándar de alumina	53N58	53N59	53N60	53N61	53N61S	
Large Stubby Gas Lens Set-up / Configuración de gas lens largo achaparrado								
G	Gasket Insulator	Empaque aislador		54N63-20	54N63-20	54N63-20	54N63-20	
F	22A Collet	Mordaza 22A			22N22AL	22N23AL	22N24AL	
	22B Collet	Mordaza 22B			22N22BL	22N23BL	22N24BL	
H	Gas Lens Collet Body	Portamordaza gas lens		45V0204S	45V116S	45V64S	995795S	
I	Alumina Nozzle Standard	Boquilla estándar de alumina			57N75		57N74	53N88



## 250 Amp Water-Cooled Torches Torch Packages & Parts Breakdown

## Antorchas refrigeradas por agua 250 A Ensamblajes de antorchas y desglose de piezas

Available TIG Torches

Antorchas TIG disponibles

Part#	Description	Descripción	Part#	Description	Descripción
20	Water Cooled Torch 250 Amp	Antorcha refrigeradas por agua 250 A	20F	Flex Torch 250 Amp	Antorcha flexible 250A
20-12	Torch Package, Vinyl, 12.5'	Ensamblaje de antorcha, vinilo, 12.5'	20F-12	Torch Package, Vinyl, 12.5'	Ensamblaje de antorcha, vinilo, 12.5'
20-12-R	Torch Package, Rubber, 12.5'	Ensamblaje de antorcha, goma, 12.5'	20F-12-R	Torch Package, Rubber, 12.5'	Ensamblaje de antorcha, goma, 12.5'
20-25	Torch Package, Vinyl, 25'	Ensamblaje de antorcha, vinilo, 25'	20F-25	Torch Package, Vinyl, 25'	Ensamblaje de antorcha, vinilo, 25'
20-25-R	Torch Package, Rubber, 25'	Ensamblaje de antorcha, goma, 25'	20F-25-R	Torch Package, Rubber, 25'	Ensamblaje de antorcha, goma, 25'
20M	Torch with Valve 250 Amp	Antorcha flexible 250A	25	Flex 180° Torch with Valve 250 Amp	Antorcha con válvula 250A
20M-12	Torch Package, Vinyl, 12.5'	Ensamblaje de antorcha, vinilo, 12.5'	25-12	Torch Package, Vinyl, 12.5'	Ensamblaje de antorcha, vinilo, 12.5'
20M-12-R	Torch Package, Rubber, 12.5'	Ensamblaje de antorcha, goma, 12.5'	25-12-R	Torch Package, Rubber, 12.5'	Ensamblaje de antorcha, goma, 12.5'
20M-25	Torch Package, Vinyl, 25'	Ensamblaje de antorcha, vinilo, 25'	25-25	Torch Package, Vinyl, 25'	Ensamblaje de antorcha, vinilo, 25'
20M-25-R	Torch Package, Rubber, 25'	Ensamblaje de antorcha, goma, 25'	25-25-R	Torch Package, Rubber, 25'	Ensamblaje de antorcha, goma, 25'
20P	180° Pencil Torch 250 Amp	Antorcha estilo lápiz 250A			
20P-12-R	Torch Package, Rubber, 12.5'	Ensamblaje de antorcha, goma, 12.5'	20P-25	Torch Package, Vinyl, 25'	Ensamblaje de antorcha, vinilo, 25'
20P-12	Torch Package, Vinyl, 12.5'	Ensamblaje de antorcha, vinilo, 12.5'	20P-25-R	Torch Package, Rubber, 25'	Ensamblaje de antorcha, goma, 25'

Torch Package Includes: Torch Body, Handle, Power Cable, Water & Gas Hoses and insulator, and medium back cap

El ensamblaje de la antorcha incluye: Cuerpo de la antorcha, Empuñadura, cable de alimentación, mangueras de agua y gas, aislador, y tapa trasera mediana

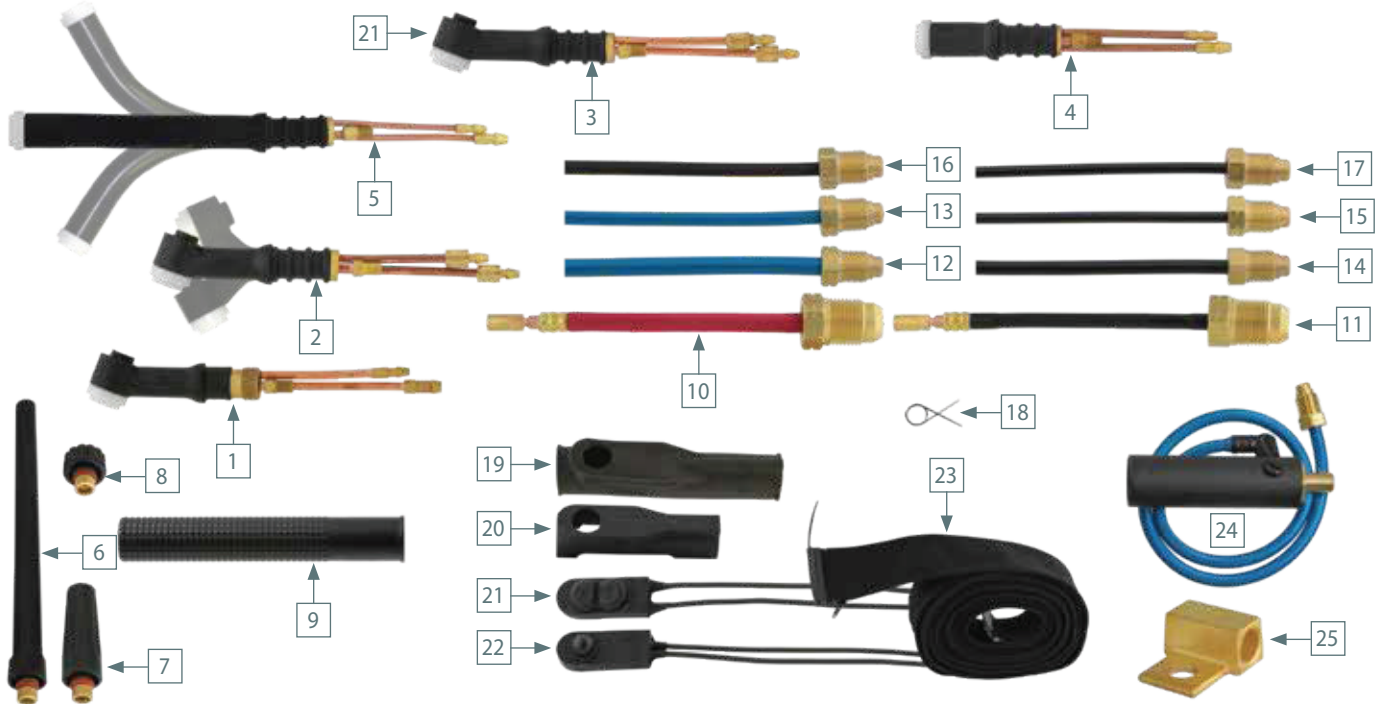

#	Part#	Description	Descripción	#	Part#	Description	Descripción
1	20	Torch Body	Cuerpo de la antorcha	14	45V07	Water Hose, Vinyl, 12.5'	Manguera de agua, vinilo, 12.5'
2	20F	Flex Torch Body	Cuerpo de la antorcha flexible	15	45V08	Water Hose, Vinyl, 25'	Manguera de agua, vinilo, 25'
3	20M	Torch Body	Cuerpo de la antorcha	16	45V07M	Water Hose, Vinyl, 12.5'	Manguera de agua, vinilo, 12.5'
4	20P	180° Torch Body	Cuerpo de la antorcha 180°	17	45V08M	Water Hose, Vinyl, 25'	Manguera de agua, vinilo, 25'
5	25	180° Flex Torch Body	Cuerpo de la antorcha flexible 180°	18	45V09R	Gas Hose, Rubber, 12.5'	Manguera de gas, goma, 12.5'
6	41V24	Long Back Cap	Tapa trasera larga	19	45V10R	Gas Hose, Rubber, 25'	Manguera de gas, goma, 25'
7	41V35	Medium Back Cap	Tapa trasera mediana	20	45V09	Gas Hose, Vinyl, 12.5'	Manguera de gas, vinilo, 12.5'
8	41V33	Short Back Cap	Tapa trasera corta	21	45V10	Gas Hose, Vinyl, 25'	Manguera de gas, vinilo, 25'
9	53N06	Handle (20)	Empuñadura (20)	22	53N04	Hose Clamp	Abrazadera de la manguera
	H-100	Handle (20M, 20P, 20F, 25)	Empuñadura (20M, 20P, 20F, 25)	19	BS-1	Rubber Switch Boot	Bota del interruptor, de goma
10	45V03R	Power Cable, Rubber, 12.5'	Cable de alimentación, goma, 12.5'	20	BS-1S	Snap-on Switch Boot	Bota del interruptor, cierre a presión
	45V04R	Power Cable, Rubber, 25'	Cable de alimentación, goma, 25'	21	SW2-0	On-Off Switch	Interruptor encendido / apagado
11	45V03	Power Cable, Vinyl, 12.5'	Cable de alimentación de vinilo, 12.5'	22	SW1	Switch, Momentary Bulb	Interruptor, bulbo momentáneo
	45V04	Power Cable, Vinyl, 25'	Cable de alimentación de vinilo, 25'	23	CC-3-10	Cable Cover, 3"X10'	Cobertor del cable, 3"X10'
12	45V07R	Water Hose, Rubber, 12.5'	Manguera de agua, goma, 12.5'		CC-3-22	Cable Cover, 3"X22'	Cobertor del cable, 3"X22'
	45V08R	Water Hose, Rubber, 25'	Manguera de agua, goma, 25'	24	DA-1820L	Disinse 50mm, w/24" Aux. Hose	Disinse 50mm, Manguera auxiliar de 24"
13	45V07RM	Water Hose, Rubber, 12.5'	Manguera de agua, goma, 12.5'	25	45V11	Power Cable Adapter	Adaptador para cable de alimentación
	45V08RM	Water Hose, Rubber, 25'	Manguera de agua, goma, 25'				



## 350 Amp Water-Cooled Torches Torch Packages & Parts Breakdown

## Antorchas refrigeradas por agua 350 A Ensamblajes de antorchas y desglose de piezas

### Available TIG Torches

### Antorchas TIG disponibles

Part#	Description	Descripción	Part#	Description	Descripción
18	Water Cooled Torch 350 Amp	Antorcha refrigeradas por agua 350A	18V	Torch with Valve 350 Amp	Antorcha con válvula 350A
18-12	Torch Package, Vinyl, 12.5'	Ensamblaje de antorcha, vinilo, 12.5'	18V-12	Torch Package, Vinyl, 12.5'	Ensamblaje de antorcha, vinilo, 12.5'
18-12-R	Torch Package, Rubber, 12.5'	Ensamblaje de antorcha, goma, 12.5'	18V-12-R	Torch Package, Rubber, 12.5'	Ensamblaje de antorcha, goma, 12.5'
18-25	Torch Package, Vinyl, 25'	Ensamblaje de antorcha, vinilo, 25'	18V-25	Torch Package, Vinyl, 25'	Ensamblaje de antorcha, vinilo, 25'
18-25-R	Torch Package, Rubber, 25'	Ensamblaje de antorcha, goma, 25'	18V-25-R	Torch Package, Rubber, 25'	Ensamblaje de antorcha, goma, 25'
18F	Flex Torch 350 Amp	Antorcha flexible 350A	18P	Machine Torch 500 Amp 180°	Antorcha 500A 180°
18F-12	Torch Package, Vinyl, 12.5'	Ensamblaje de antorcha, vinilo, 12.5'	18P-12-R	Torch Package, Rubber, 12.5'	Ensamblaje de antorcha, goma, 12.5'
18F-12-R	Torch Package, Rubber, 12.5'	Ensamblaje de antorcha, goma, 12.5'	18P-25-R	Torch Package, Rubber, 25'	Ensamblaje de antorcha, goma, 25'
18F-25	Torch Package, Vinyl, 25'	Ensamblaje de antorcha, vinilo, 25'			
18F-25-R	Torch Package, Rubber, 25'	Ensamblaje de antorcha, goma, 25'			

Torch Package Includes: Torch Body, Handle, Power Cable, Water & Gas Hoses and insulator, and large back cap  
El ensamblaje de la antorcha incluye: Cuerpo de la antorcha, Empuñadura, cable de alimentación, mangueras de agua y gas, aislador, y tapa trasera larga

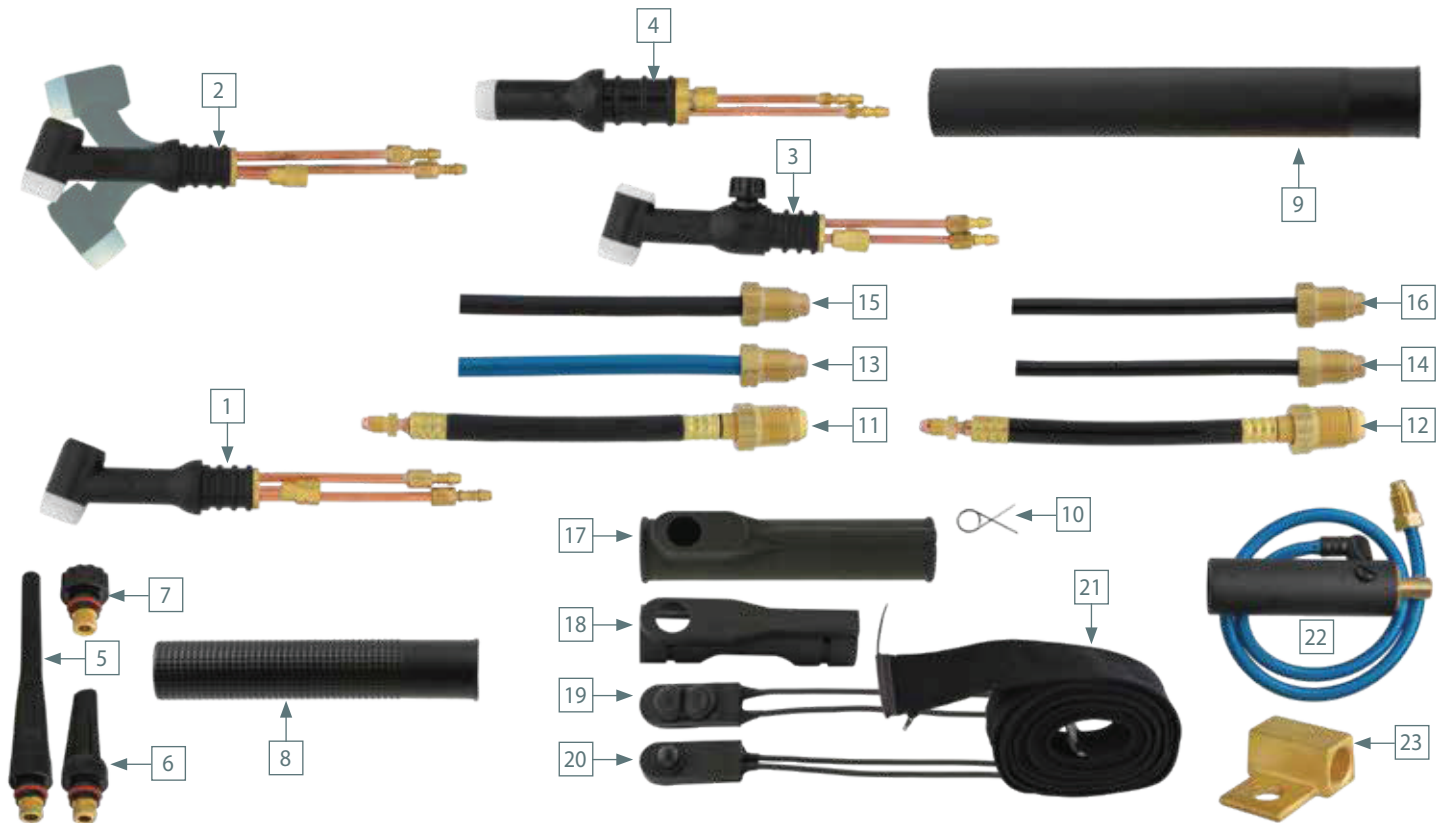

#	Part#	Description	Descripción	#	Part#	Description	Descripción
1	18	Torch Body	Cuerpo de la antorcha	14	40V74	Water Hose, Vinyl, 12.5'	Manguera de agua, vinilo, 12.5'
2	18F	Flex Torch Body	Cuerpo de la antorcha flexible	41V32	Water Hose, Vinyl, 25'	Manguera de agua, vinilo, 25'	
3	18V	Torch Body with Valve	Cuerpo de la antorcha con válvula	15	40V75R	Gas Hose, Rubber, 12.5'	Manquera de gas, goma, 12.5'
4	18P	180° Torch Body	Cuerpo de la antorcha 180°	41V30R	Gas Hose, Rubber, 25'	Manquera de gas, goma, 25'	
5	57Y02	Long Back Cap	Tapa trasera larga	16	40V75	Gas Hose, Vinyl, 12.5'	Maguera de gas, vinilo, 12.5'
6	300M	Medium Back Cap	Tapa trasera mediana	41V30R	Gas Hose, Vinyl, 25'	Maguera de gas, vinilo, 25'	
7	57Y04	Short Back Cap	Tapa trasera corta	17	BL-1	Rubber Switch Boot	Bota del interruptor, de goma
8	H-200	Handle (18, 18F, 18V)	Empuñadura(18, 18F, 18V)	18	BL-1S	Snap-on Switch Boot	Bota del interruptor, cierre a presión
9	18PB	Handle (18P)	Empuñadura(18P)	19	SW2-0	On-Off Switch	Interruptor encendido / apagado
10	53N04	Hose Clamp	Abrazadera de la manguera	20	SW1	Switch, Momentary Bulb	Interruptor, bulbo momentáneo
11	40V64R	Power Cable, Rubber	Cable de alimentación, goma, 12.5'	SW1F	Switch, Momentary Flat	Interruptor, plano momentáneo	
12	41V29R	Power Cable, Rubber	Cable de alimentación, goma, 25'	21	CC-3-10	Cable Cover, 3"X10'	Cobertor del cable, 3"X10'
13	40V64	Power Cable, Vinyl	Cable de alimentación de vinilo, 12.5'	22	CC-3-22	Cable Cover, 3"X22'	Cobertor del cable, 3"X22'
	41V29	Power Cable, Vinyl	Cable de alimentación de vinilo, 25'	23	DA-1820L	Dinse 50mm, w/24" Aux. Hose	Dinse 50mm, Manguera auxiliar de 24"
	40V74R	Water Hose, Rubber, 12.5'	Manguera de agua, goma, 12.5'		45V11	Power Cable Adapter	Adaptador para cable de alimentación
	41V32R	Water Hose, Rubber, 25'	Manguera de agua, goma, 25'				



## 500 Amp Water-Cooled Torch Torch Packages & Parts Breakdown

## Antorchas refrigeradas por agua 500 A Ensamblajes de antorchas y desglose de piezas

### Available TIG Torches

### Antorchas TIG disponibles

Part#	Description	Descripción	Part#	Description	Descripción
12-12	Torch Package, Rubber, 12.5'	Ensamblaje de antorcha, goma, 12.5'	12-25	Torch Package, Rubber, 25'	Ensamblaje de antorcha, goma, 25'
Torch Package Includes: Torch Body, Handle, Power Cable, Water & Gas Hoses, insulator, and long back cap El ensamblaje de la antorcha incluye: Cuerpo de la antorcha, Empuñadura, cable de alimentación, mangueras de agua y gas, aislador, y tapa trasera larga					



#	Part#	Description	Descripción
1	12	Torch Body	Cuerpo de la antorcha
2	56Y44	Back Cap, Long	Tapa trasera larga
3	56Y45	Back Cap, Short	Tapa trasera corta
4	40V84R	Power Cable, Rubber, 12.5'	Cable de alimentación, goma, 12.5'
5	40V84RL	Power Cable, Rubber, 25'	Cable de alimentación, goma, 25'
6	40V83R	Water Hose, Rubber, 12.5'	Manguera de agua, goma, 12.5'
7	40V83RL	Water Hose, Rubber, 25'	Manguera de agua, goma, 25'
8	40V82R	Gas Hose, Rubber, 12.5'	Manguera de gas, goma, 12.5'
9	40V82RL	Gas Hose, Rubber, 25'	Manguera de gas, goma, 25'
10	85WP13	Handle	Empuñadura
	CC-4-10	Cable Cover, 4'X10'	Cobertor de cable, 4'X10'
	CC-4-22	Cable Cover, 4'X22'	Cobertor de cable, 4'X22'
	45V11	Power Cable Adapter	Adaptador para cable de alimentación
	12NG	Gasket Insulator	Empaque aislador

#	Electrode Diameter	1/16"	3/32"	1/8"	5/32"	3/16"	1/4"
	Diametro del electrodo	(1.6mm)	(2.4mm)	(3.2mm)	(4.0mm)	(4.8mm)	(6.4mm)
	Tamaño de la boquilla	#4 (1/4")	#5 (5/16")	#6 (3/8")	#7 (7/16")	#8 (1/2")	#10 (5/8")
	Nozzle Size	#4 (1/4")	#5 (5/16")	#6 (3/8")	#7 (7/16")	#8 (1/2")	#10 (5/8")
Standard Set-up / Ensamble estándar							
A	Collet	Mordaza	85Z14	85Z15	85Z16	85Z17	85Z18
B	Collet Body	Portamordaza	11WP65	11WP65	11WP65	11WP65	11WP65
C	Alumina Nozzle	Boquilla estándar de alumina	14N57	14N58	14N59	14N60	14N61
Gas Lens Set-up / Ensamble para gas lens							
D	Gasket Insulator	Empaque aislador	12GLG	12GLG	12GLG	12GLG	12GLG
E	Gas Lens Collet Body	Portamordaza, gas lens	11GL16	11GL32	11GL18	11GL53	11GL36
F	Alumina Nozzle	Boquilla estándar de alumina		57N75		57N74	53N88
	Alumina Nozzle Long	Boquilla larga de alumina		57N75L		57N74L	53N88L
	Alumina Nozzle XLong	Boquilla Xlarga de alumina		57N75XL		57N74XL	53N88XL

## 500 Amp Water-Cooled Torches Torch Packages & Parts Breakdown

## Antorchas refrigeradas por agua 500 A Ensamblajes de antorchas y desglose de piezas

### Available TIG Torches

### Antorchas TIG disponibles

Part#	Description	Descripción	Part#	Description	Descripción
27A-3	Torch Package, Rubber, 3'	Ensamblaje de antorcha, goma, 3'	27B-3	Torch Package, Rubber, 3'	Ensamblaje de antorcha, goma, 3'
27A-12	Torch Package, Rubber, 12.5'	Ensamblaje de antorcha, goma, 12.5'	27B-12	Torch Package, Rubber, 12.5'	Ensamblaje de antorcha, goma, 12.5'
27A-25	Torch Package, Rubber, 25'	Ensamblaje de antorcha, goma, 25'	27B-25	Torch Package, Rubber, 25'	Ensamblaje de antorcha, goma, 25'

Torch Package Includes: Torch Body, Handle, Power Cable, Water & Gas Hoses and insulator  
El ensamblaje de la antorcha incluye: Cuerpo de la antorcha, Empuñadura, cable de alimentación, mangueras de agua y gas, aislador

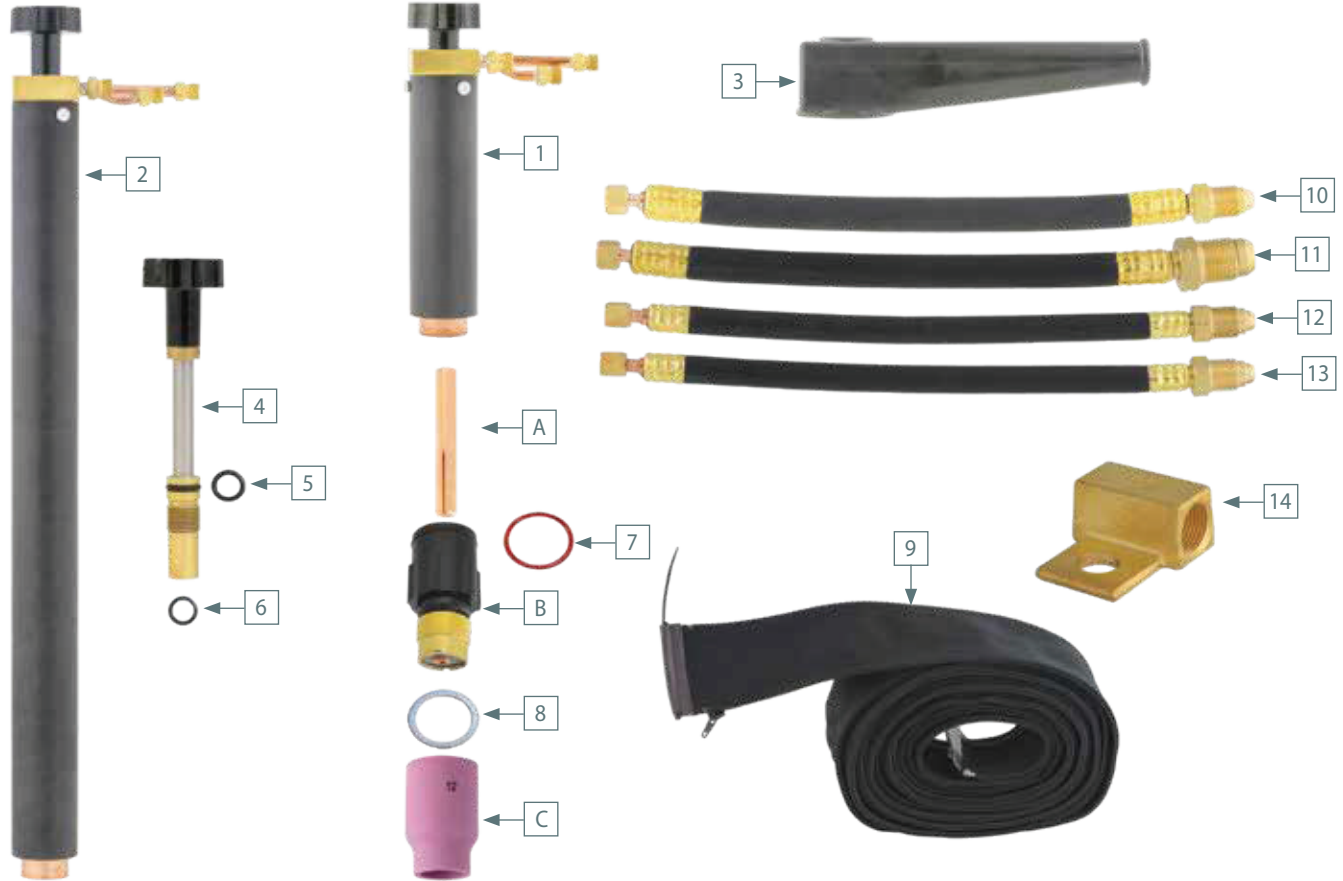

#	Part#	Description	Descripción	#	Part#	Description	Descripción
1	27A	Torch Body 9"	Cuerpo de la antorcha 9"	10	40V84R-3	Power Cable, Rubber, 3	Cable de alimentación, goma, 3
2	27B	Torch Body 20"	Cuerpo de la antorcha 20"	11	40V84R	Power Cable, Rubber, 12.5	Cable de alimentación, goma, 12.5
3	27-12	Insulating Boot	Bota aislante		40V84RL	Power Cable, Rubber, 25'	Cable de alimentación, goma, 25
4	27-13A	Shaft Assembly (27A)	Ensamble del eje (27A)	12	40V83R-3	Water Hose, Rubber, 3'	Manguera de agua, goma, 3
	27-13B	Shaft Assembly (27B)	Ensamble del eje (27B)		40V83R	Water Hose, Rubber, 12.5'	Manguera de agua, goma, 12.5
5	27-13-2	O-ring	Anillo O		40V83RL	Water Hose, Rubber, 25'	Manguera de agua, goma, 25
6	27-13-3	O-ring	Anillo O	13	40V82R-3	Gas Hose, Rubber, 3'	Manguera de gas, goma, 3'
7	181W89	O-ring	Anillo O		40V82R	Gas Hose, Rubber, 12.5'	Manguera de gas, goma, 12.5'
8	57N56	Gasket Insulator	Empaque aislador		40V82RL	Gas Hose, Rubber, 25'	Manguera de gas, goma, 25
9	CC-4-10	Cable Cover, 4'X10'	Cobertor de cable, 4'X10'	14	45V11	Power Cable Adapter	Adaptador para cable de alimentación
	CC-4-22	Cable Cover, 4'X22'	Cobertor de cable, 4'X22'				

#		Electrode Diameter Diametro del electrodo	.040" (1.0mm)	1/16" (1.6mm)	3/32" (2.4mm)	1/8" (3.2mm)	5/32" (4.0mm)	3/16" (4.8mm)	1/4" (6.4mm)
	Nozzle Size Tamaño de la boquilla		#4 (1/4")	#5 (5/16")	#6 (3/8")	#7 (7/16")	#8 (1/2")	#10 (5/8")	#12 (3/4")
Standard Set-up / Ensamble estándar									
A	Collet	Mordaza	57N45	57N46	57N47	57N48	57N49	57N50	57N51
B	Gas Lens Collet Body	Portamordaza, gas lens	49V22	49V23	49V24	49V25	49V26	49V27	49V28
C	Alumina Nozzle	Boquilla estándar de alumina			57N75	57N74	53N88	53N87	
	Alumina Nozzle Long	Boquilla larga de alumina			57N75L	57N74L	53N88L	53N87L	
	Alumina Nozzle XLong	Boquilla Xlarga de alumina			57N75XL	57N74XL	53N88XL	53N87XL	





Description	Descripción	Electrode Diameter Diámetro del electrodo	.020" (0.5mm)	.040" (1.0mm)	1/16" (1.6mm)	3/32" (2.4mm)	1/8" (3.2mm)	5/32" (4.0mm)
	Nozzle Size Tamaño de la boquilla	#3 (3/16")	#4 (1/4")	#5 (5/16")	#6 (3/8")	#7 (7/16")	#8 (1/2")	#10 (5/8")
<b>Standard Set-up / Configuración estándar</b>								
A	Gasket Insulator	Empaque aislador	598882	598882	598882	598882	598882	
B	Collet	Mordaza	13N20	13N21	13N22	13N23	13N24	
C	Collet Body	Portamordaza	13N25	13N26	13N27	13N28	13N29	
D	Alumina Nozzle Standard	Boquilla de alumina estándar	13N08	13N09	13N10	13N11	13N12	13N13
E	Alumina Nozzle Long	Boquilla de alumina largo	A796F70	A796F71	A796F72	A796F73		
F	Alumina Nozzle Extra Long	Boquilla de alumina exta largo	A796F74	A796F75	A796F76	A796F77		
G	Lava Nozzle Standard	Boquilla de lava estándar		13N14	13N15	13N16	13N17	13N18
H	Lava Nozzle Long	Boquilla de lava larga	796F70	796F71	796F72	796F73		
I	Lava Nozzle Extra Long	Boquilla de lava extra larga	796F74	796F75	796F76	796F77		
<b>Small Gas Lens Set-up / Configuración de gas lens pequeño</b>								
A	Gasket Insulator	Empaque aislador	598882	598882	598882	598882	598882	
B	Collet	Mordaza	13N20	13N21	13N22	13N23	13N24	
J	Gas Lens Collet Body	Portamordaza	45V41	45V42	45V43	45V44	45V45	
K	Alumina Nozzle Standard	Boquilla de alumina estándar	53N58	53N59	53N60	53N61	53N61S	
<b>Large Stubby Gas Lens Set-up / Configuración de gas lens largo achaparrado</b>								
L	Gasket Insulator	Empaque aislador	54N63-20	54N63-20	54N63-20	54N63-20	54N63-20	
M	Gas Lens Collet	Mordaza	13N20L	13N21L	13N22L	13N23L	13N24L	
N	Gas Lens Collet Body	Portamordaza	45V0204S	45V0204S	45V116S	45V64S	99S795S	
O	Alumina Nozzle Standard	Boquilla de alumina estándar			57N75		57N74	53N88



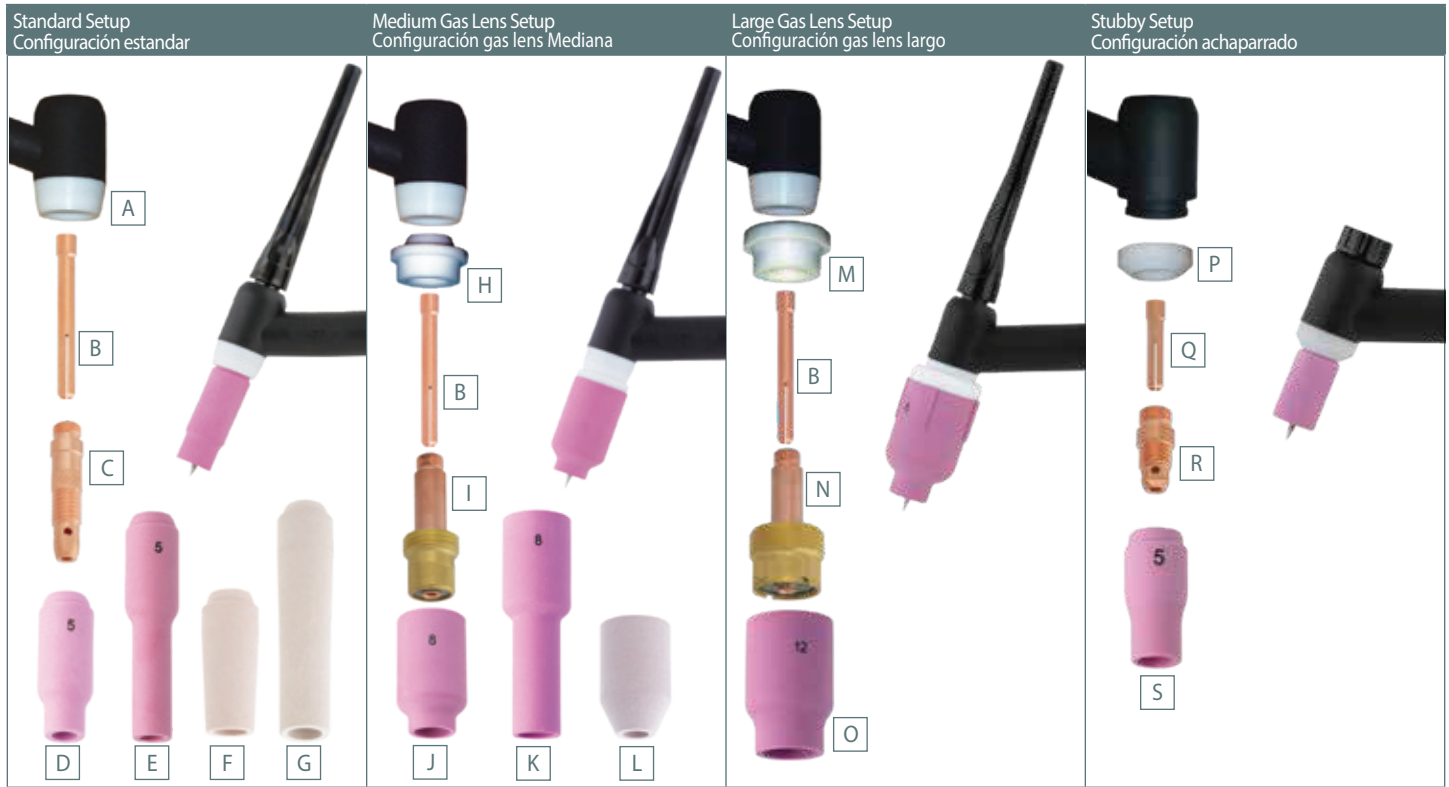

Description Descripción	Electrode Diameter Diámetro del electrodo	Nozzle Size / Tamaño de la boquilla									
		.020" (0.5mm)	.040" (1.0mm)	1/16" (1.6mm)	3/32" (2.4mm)	1/8" (3.2mm)	5/32" (4.0mm)				
		#4 (1/4")	#5 (5/16")	#6 (3/8")	#7 (7/16")	#8 (1/2")	#10 (5/8")	#12 (3/4")			
<b>Standard Set-up / Configuración estándar</b>											
A	Gasket Insulator	Empaque aislador	18CG	18CG	18CG	18CG	18CG	18CG			
B	Collet	Mordazda	10N21	10N22	10N23	10N24	10N25	54N20			
C	Collet Body	Portamordaza	10N29	10N30	10N31	10N32	10N28	406488			
D	Alumina Nozzle Standard	Boquilla de alumina estándar	10N50	10N49	10N48	10N47	10N46	10N45		10N44	
E	Alumina Nozzle Long	Boquilla de alumina larga		10N49L	10N48L	10N47L					
F	Lava Nozzle Standard	Boquilla de lava estándar	105Z43	105Z42	105Z44	105Z45	08N78	08N79	08N80		
G	Lava Nozzle Long	Boquilla de lava larga	12N03	105Z60	12N02	105Z61					
<b>Medium Gas Lens Set-up / Configuración gas lens Mediana</b>											
H	Gasket Insulator	Empaque aislador	54N01	54N01	54N01	54N01	54N01	54N01			
B	Collet	Mordazda	10N21	10N22	10N23	10N24	10N25	54N20			
I	Gas Lens Collet Body	Portamordaza gas lens	45V29	45V24	45V25	45V26	45V27	45V28			
J	Alumina Nozzle Standard	Boquilla de alumina estándar	54N18	54N17	54N16	54N15	54N14	54N19			
K	Alumina Nozzle Long	Boquilla de alumina larga		54N17L	54N16L	54N15L	54N14L				
L	Lava Nozzle Standard	Boquilla de lava estándar	54N35	54N34	54N33	54N32	54N31	54N36			
<b>Large Gas Lens Set-up / Configuración gas lens largo</b>											
M	Gasket Insulator	Empaque aislador	54N63	54N63	54N63	54N63	54N63	54N63			
B	Collet	Mordazda	10N21	10N22	10N23	10N24	10N25	54N20			
N	Gas Lens Collet Body	Portamordaza gas lens	45V0204	45V0204	45V116	45V64	995795	45V63			
O	Alumina Nozzle Standard	Boquilla de alumina estándar			57N75	57N74	53N88	53N87			
	Alumina Nozzle Long	Boquilla de alumina de larga			57N75L	57N74L	#15 (15/16")		53N89		
	Alumina Nozzle Extra Long	Boquilla de alumina exta larga			57N75XL	57N74XL					
<b>Stubby Collet Body Set-up / Configuración de portamordaza achaparrado</b>											
P	Gasket Insulator	Empaque aislador	18CG20	18CG20	18CG20	18CG20	18CG20				
Q	Stubby Collet	Mordaza achaparrado	10N21S	10N22S	10N23S	10N24S	10N25S				
R	Stubby Collet Body	Portamordaza achaparrado	17CB20	17CB20	17CB20	17CB20	17CB20				
S	Alumina Nozzle Standard	Patron de boquilla de alumina	13N08	13N09	13N10	13N11	13N12	13N13			



#	Part#	Description	Descripción	Length Longitud	Torches Antorchas
Back Caps / Tapas traseras					
1	57Y02	Long Back Cap	Tapa trasera larga	4 3/4"	17, 18, 26
2	57Y04	Short Back Cap	Tapa trasera corta	1"	
3	300M	Medium Back Cap	Tapa trasera mediana	2 1/4"	
4	98W18	O-ring	O-ring		9, 20
5	41V24	Long Back Cap	Tapa trasera larga	5 3/4"	
6	41V33	Short Back Cap	Tapa trasera corta	5/8" 1	
7	41V35	Medium Back Cap	Tapa trasera mediana	7/8"	12
8	98W77	O-ring	O-ring		
9	56Y44	Long Back Cap	Tapa trasera larga	4 1/2"	
10	56Y45	Short Back Cap	Tapa trasera corta	1 3/16"	

#	Part#	Description	Descripción	Size Tamaño	Torches Antorchas
Collets / Mordazas					
11	10N21	Standard	Estándar	.020" (0.5mm)	17, 18, 26
	10N22	Standard	Estándar	.040" (1.0mm)	
	10N23	Standard	Estándar	1/16" (1.6mm)	
	10N24	Standard	Estándar	3/32" (2.4mm)	
	10N25	Standard	Estándar	1/8" (3.2mm)	
	54N20	Standard	Estándar	5/32" (4.0mm)	
12	10N21S	Stubby	Achaparrado	.020" (0.5mm)	9, 20
	10N22S	Stubby	Achaparrado	.040" (1.0mm)	
	10N23S	Stubby	Achaparrado	1/16" (1.6mm)	
	10N24S	Stubby	Achaparrado	3/32" (2.4mm)	
	10N25S	Stubby	Achaparrado	1/8" (3.2mm)	
	13N20	Standard	Estándar	.020" (0.5mm)	
	13N21	Standard	Estándar	.040" (1.0mm)	
	13N22	Standard	Estándar	1/16" (1.6mm)	
	13N23	Standard	Estándar	3/32" (2.4mm)	
	13N24	Standard	Estándar	1/8" (3.2mm)	
	13N20L	Gas Lens	Gas lens	.020" (0.5mm)	22B
	13N21L	Gas Lens	Gas lens	.040" (1.0mm)	
	13N22L	Gas Lens	Gas lens	1/16" (1.6mm)	
	13N23L	Gas Lens	Gas lens	3/32" (2.4mm)	
	13N24L	Gas Lens	Gas lens	1/8" (3.2mm)	
	22N22A	Standard	Estándar	1/16" (1.6mm)	
	22N22AL	Gas Lens	Gas lens	1/16" (1.6mm)	
	22N23A	Standard	Estándar	3/32" (2.4mm)	
	22N23AL	Gas Lens	Gas lens	3/32" (2.4mm)	
	22N24A	Standard	Estándar	1/8" (3.2mm)	
	22N24AL	Gas Lens	Gas lens	1/8" (3.2mm)	
	22N22B	Standard	Estándar	1/16" (1.6mm)	27
	22N22BL	Gas Lens	Gas lens	1/16" (1.6mm)	
	22N23B	Standard	Estándar	3/32" (2.4mm)	
	22N23BL	Gas Lens	Gas lens	3/32" (2.4mm)	
	22N24B	Standard	Estándar	1/8" (3.2mm)	
	22N24BL	Gas Lens	Gas lens	1/8" (3.2mm)	
20	24C332	Standard	Estándar	3/32" (2.4mm)	24
	53N14	Standard	Estándar	1/16" (1.6mm)	
	53N15	Standard	Estándar	.020" (0.5mm)	
	53N16	Standard	Estándar	.040" (1.0mm)	
	24GLC332	Gas Lens	Gas lens	3/32" (2.4mm)	
	53N62	Gas Lens	Gas lens	.020" (0.5mm)	
	53N63	Gas Lens	Gas lens	.040" (1.0mm)	
	53N64	Gas Lens	Gas lens	1/16" (1.6mm)	
22	57N45	Standard	Estándar	.040" (1.0mm)	27
	57N46	Standard	Estándar	1/16" (1.6mm)	
	57N47	Standard	Estándar	3/32" (2.4mm)	
	57N48	Standard	Estándar	1/8" (3.2mm)	
	57N49	Standard	Estándar	5/32" (4.0mm)	
	57N50	Standard	Estándar	3/16" (4.8mm)	
	57N51	Standard	Estándar	1/4" (6.4mm)	



#	Part#	Description	Descripción	Size Tamaño	Torches Antorchas
Valves / válvulas					
23	VS-1	Valve Stem	Válvulas	1 1/8"	26FV, 26V
24	VS-2	Valve Stem	Válvulas	15/16"	9FV, 9V, 17FV, 17V, 18V
25	VS-0	O-ring	O-ring		

# TIG CONSUMABLES

## Collets, Collet Bodies, & Gas lenses

# CONSUMIBLES TIG

## Mordaza, Portamordaza y Gas lenses



#	Part#	Description	Descripción	Size Tama ño	Torches Antorchas
Collets / Mordaza					
1	85Z14	Standard	Estándar	1/16" (1.6mm)	12
	85Z15	Standard	Estándar	3/32" (2.4mm)	
	85Z16	Standard	Estándar	1/8" (3.2mm)	
	85Z17	Standard	Estándar	5/32" (4.0mm)	
	85Z18	Standard	Estándar	3/16" (4.8mm)	
	85Z19	Standard	Estándar	1/4" (6.4mm)	

#	Part#	Description	Descripción	Size Tama ño	Torches Antorchas
Collet Bodies / Portamordaza					
2	10N28	Standard	Estándar	1/8" (3.2mm)	17, 18, 26
	10N29	Standard	Estándar	.020" (0.5mm)	
	10N30	Standard	Estándar	.040" (1.0mm)	
	10N31	Standard	Estándar	1/16" (1.6mm)	
	10N32	Standard	Estándar	3/32" (2.4mm)	
	406488	Standard	Estándar	5/32" (4.0mm)	
3	13N25	Standard	Estándar	.020" (0.5mm)	9, 20
	13N26	Standard	Estándar	.040" (1.0mm)	
	13N27	Standard	Estándar	1/16" (1.6mm)	
	13N28	Standard	Estándar	3/32" (2.4mm)	
	13N29	Standard	Estándar	1/8" (3.2mm)	
4	24CB332	Standard	Estándar	3/32" (2.4mm)	24
	53N17	Standard	Estándar	.020" (0.5mm)	
	53N18	Standard	Estándar	.040" (1.0mm)	
	53N19	Standard	Estándar	1/16" (1.6mm)	
5	11WP65	Standard	Estándar	All/Todos	12
6	17CB20	Stubby	Achaparrado	All/Todos	17, 18, 26

#	Part#	Description	Descripción	Size Tama ño	Torches Antorchas
Gas Lenses / Portamordazas gas lens					
7	11GL16	Standard	Estándar	1/16" (1.6mm)	12
	11GL18	Standard	Estándar	1/8" (3.2mm)	
	11GL32	Standard	Estándar	3/32" (2.4mm)	
	11GL53	Standard	Estándar	5/32" (4.0mm)	
	11GL36	Standard	Estándar	1/4" (4.8mm)	
8	45V24	Medium	Mediono	.040" (1.0mm)	17, 18, 26
	45V25	Medium	Mediono	1/16" (1.6mm)	
	45V26	Medium	Mediono	3/32" (2.4mm)	
	45V27	Medium	Mediono	1/8" (3.2mm)	
	45V28	Medium	Mediono	5/32" (4.0mm)	
	45V29	Medium	Mediono	.020" (0.5mm)	
9	45V0204	Large	Grande	.020-.040"	17, 18, 26
	45V116	Large	Grande	1/16" (1.6mm)	
	45V63	Large	Grande	5/32" (4.0mm)	
	45V64	Large	Grande	3/32" (2.4mm)	
	995795	Large	Grande	1/8" (3.2mm)	
10	45V41	Standard	Estándar	.020" (0.5mm)	9, 20
	45V42	Standard	Estándar	.040" (1.0mm)	
	45V43	Standard	Estándar	1/16" (1.6mm)	
	45V44	Standard	Estándar	3/32" (2.4mm)	
	45V45	Standard	Estándar	1/8" (3.2mm)	
11	45V0204S	Stubby	Achaparrado	.020-.040"	9, 20
	45V116S	Stubby	Achaparrado	1/16" (1.6mm)	
	45V64S	Stubby	Achaparrado	3/32" (2.4mm)	
	995795S	Stubby	Achaparrado	1/8" (3.2mm)	
12	49V22	Standard	Estándar	.040" (1.0mm)	27
	49V23	Standard	Estándar	1/16" (1.6mm)	
	49V24	Standard	Estándar	3/32" (2.4mm)	
	49V25	Standard	Estándar	1/8" (3.2mm)	
	49V26	Standard	Estándar	5/32" (4.0mm)	
	49V27	Standard	Estándar	3/16" (4.8mm)	
	49V28	Standard	Estándar	1/4" (6.4mm)	





Torches/Antorchas 17, 18, 26

#	Part #	Size Tamaño	Orifice Orificio	Length Longitud
<b>Standard / Estándar</b>				
1	10N44	# 12	3/4"	1 7/8"
	10N45	# 10	5/8"	1 7/8"
	10N46	# 8	1/2"	1 7/8"
	10N47	# 7	7/16"	1 7/8"
	10N48	# 6	3/8"	1 7/8"
	10N49	# 5	5/16"	1 7/8"
	10N50	# 4	1/4"	1 7/8"
2	10N47L	# 7	7/16"	3"
	10N48L	# 6	3/8"	3"
	10N49L	# 5	5/16"	3"
<b>Medium Gas Lens / Gas lens mediana</b>				
3	54N14	# 8	1/2"	1 5/8"
	54N15	# 7	7/16"	1 5/8"
	54N16	# 6	3/8"	1 5/8"
	54N17	# 5	5/16"	1 5/8"
	54N18	# 4	1/4"	1 5/8"
4	54N19	# 11	.700"	1 1/8"
5	54N14L	# 8	1/2"	3"
	54N15L	# 7	7/16"	3"
	54N16L	# 6	3/8"	3"
	54N17L	# 5	5/16"	3"

Torches/Antorchas 9, 17, 18, 20, 22, 26, 27

#	Part #	Size Tamaño	Orifice Orificio	Length Longitud
<b>Large Gas Lens / Gas lens largo</b>				
6	57N75	# 6	3/8"	1 7/8"
	57N74	# 8	1/2"	1 7/8"
	53N88	# 10	5/8"	1 7/8"
	53N87	# 12	3/4"	1 7/8"
7	53N89	# 15	15/16"	1 3/8"
8	57N75L	# 6	3/8"	2 3/4"
	57N74L	# 8	1/2"	2 3/4"
	53N88L	# 10	5/8"	2 3/4"
	53N87L	# 12	3/4"	2 3/4"
9	57N75XL	# 6	3/8"	3 1/4"
	57N74XL	# 8	1/2"	3 1/4"
	53N88XL	# 10	5/8"	3 1/4"
	53N87XL	# 12	3/4"	3 1/4"
10	57N75XXL	# 6	3/8"	4 3/4"
	57N74XXL	# 8	1/2"	4 3/4"
	53N88XXL	# 10	5/8"	4 3/4"
	53N87XXL	# 12	3/4"	4 3/4"

Torches/Antorchas 9, 20, 22

#	Part #	Size Tamaño	Orifice Orificio	Length Longitud
<b>Standard / Estándar</b>				
11	13N08	# 4	1/4"	1 3/16"
	13N09	# 5	5/16"	1 3/16"
	13N10	# 6	3/8"	1 3/16"
	13N11	# 7	7/16"	1 3/16"
	13N12	# 8	1/2"	1 3/16"
	13N13	# 10	5/8"	1 3/16"
<b>Long / Larga</b>				
12	A796F70	# 3	3/16"	1 15/16"
	A796F71	# 4	1/4"	1 15/16"
	A796F72	# 5	5/16"	1 15/16"
	A796F73	# 6	3/8"	1 15/16"
13	A796F74	# 3	3/16"	2 1/2"
	A796F75	# 4	1/4"	2 1/2"
	A796F76	# 5	5/16"	2 1/2"
	A796F77	# 6	3/8"	2 1/2"
<b>Small Gas Lens / Gas lens pequeño</b>				
14	53N58	# 4	1/4"	1"
	53N59	# 5	5/16"	1"
	53N60	# 6	3/8"	1"
	53N61	# 7	7/16"	1"
	53N61S	# 8	1/2"	1"

Torches/Antorchas 24

#	Part #	Size Tamaño	Orifice Orificio	Length Longitud
<b>Standard / Estándar</b>				
15	53N23A	# 3	.165"	5/8"
	53N24A	# 4	1/4"	5/8"
	53N25A	# 5	5/16"	5/8"
	53N27A	# 6	3/8"	5/8"
16	53N26A	# 6	3/8"	5/8"

Torch/Antorcha 12

#	Part #	Size Tamaño	Orifice Orificio	Length Longitud
<b>Standard / Estándar</b>				
17	14N57	# 4	1/4"	1 1/4"
	14N58	# 5	5/16"	1 1/4"
	14N59	# 6	3/8"	1 1/4"
	14N60	# 7	7/16"	1 1/4"
	14N61	# 8	1/2"	1 1/4"
	14N61-10	# 10	5/8"	1 1/4"
	14N61-12	# 12	3/4"	1 1/4"





Torches/Antorchas 17, 18, 26

#	Part #	Size Tamaño	Orifice Orificio	Length Longitud
Standard / Estándar				
1	105Z42	# 4	1/4 "	1 7/8 "
	105Z43	# 5	5/16 "	1 7/8 "
	105Z44	# 6	3/8 "	1 7/8 "
	105Z45	# 7	7/16 "	1 7/8 "
	08N78	# 8	1/2 "	1 7/8 "
	08N79	# 10	5/8 "	1 7/8 "
	08N80	# 12	3/4 "	1 7/8 "
	2	105Z60	# 5	5/16 "
105Z61		# 7	7/16 "	3 1/4 "
12N02		# 6	3/8 "	3 1/4 "
12N03		# 4	1/4 "	3 1/4 "
Medium Gas Lens / Gas lens mediana				
3	54N31	# 8	1/2 "	1 1/16 "
	54N32	# 7	7/16 "	1 1/16 "
	54N33	# 6	3/8 "	1 1/16 "
	54N34	# 5	5/16 "	1 1/16 "
	54N35	# 4	1/4 "	1 1/16 "
	54N36	# 11	1 1/16 "	1 1/16 "

Torches/Antorchas 24

#	Part #	Size Tamaño	Orifice Orificio	Length Longitud
Standard / Estándar				
4	53N23	# 3	.165"	5/8 "
	53N24	# 4	1/4 "	5/8 "
	53N25	# 5	5/16 "	5/8 "
	53N27	# 6	3/8 "	5/8 "
5	53N26	# 6	3/8 "	1 1/8 "
	53N28	# 4	1/4 "	1 1/8 "

Torches/Antorchas 9, 20, 22

#	Part #	Size Tamaño	Orifice Orificio	Length Longitud
Standard / Estándar				
6	13N14	# 4	1/4 "	1 1/8 "
	13N15	# 5	5/16 "	1 1/8 "
	13N16	# 6	3/8 "	1 1/8 "
	13N17	# 7	7/16 "	1 1/8 "
	13N18	# 8	1/2 "	1 1/8 "
	13N19	# 10	5/8 "	1 1/8 "
Standard Long / Estándar largo				
7	796F70	# 3	3/16 "	1 15/16 "
	796F71	# 4	1/4 "	1 15/16 "
	796F72	# 5	5/16 "	1 15/16 "
	796F73	# 6	3/8 "	1 15/16 "
8	796F74	# 3	3/16 "	2 1/2 "
	796F75	# 4	1/4 "	2 1/2 "
	796F76	# 5	5/16 "	2 1/2 "
	796F77	# 6	3/8 "	2 1/2 "
	796F79	# 4	1/4 "	3 1/2 "
	796F80	# 5	5/16 "	3 1/2 "



#	Part#	Description	Descripción	Use on Torches Use con antorchas
Handles / Empuñadura				
9	H100	Smooth, Push-on	Lisa, método de empuje	9, 17, 20M, 20F, 24
	53N06	Smooth, Threaded	Lisa, roscada	20, HP9, HP20
	105Z55	Smooth, Threaded	Lisa, roscada	HP17, HP24
10	H100R	Ribbed, Push-on	Acanalada, método de empuje	9, 17, 24
	105Z55R	Ribbed, Threaded	Acanalada, roscada	HP17, HP24
11	H200	Smooth, Push-on	Lisa, método de empuje	18, 26
	10N15	Smooth, Threaded	Lisa, roscada	HP18, HP26
12	H200-R	Ribbed, Threaded	Acanalada, roscada	26
	10N15R	Ribbed, Push-on	Acanalada, método de empuje	HP18, HP26
13	85WP13	Barrel	Baril	12
14	18PB	Ribbed, Push-on	Acanalada, método de empuje	18P



#	Part #	Threads Roscas	Torches Antorchas
Power Cable Adapter / Adaptador para cable de alimentación			
15	45V11	7/8 "-14LH - 5/8 "-18LH	All Water-cooled
16	105Z57	3/8 "-24RH - 5/8 "-18RH	9, 17, 24FMT, 150M
17	45V62	7/8 "-14RH - 5/8 "-18RH	26, 200M
18	53N43	3/8 "-24RH - 5/8 "-18RH	24



## Accessory Kits

## Kits de accesorios

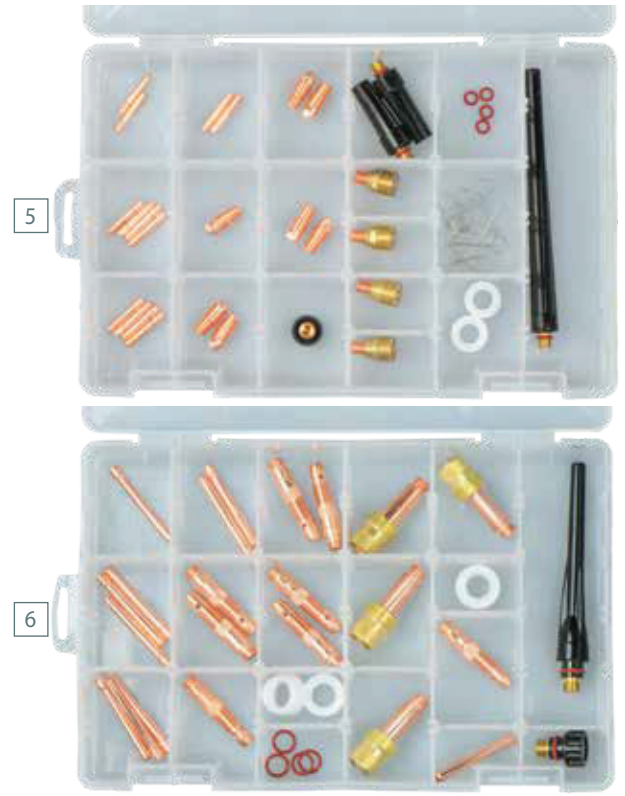

#	Part #	Contains	Contiene	Torches / ANTORCHAS
<b>Accessory Kits / Kits de accesorios</b>				
1	AK-1	1 Long Back Cap 2 Collets - .040" & 1/16 " 2 Collet Bodies - .040" & 1/16 " 3 Alumina Nozzles - #4, #5, #6 2 E3° Tungsten 7° - .040" & 1/16 "	1 Tapa trasera larga 2 Mordazas - .040" & 1/16 " 2 Portamordazas - .040" & 1/16 " 3 Boquillas alumina - #4, #5, #6 2 E3° Tungsteno 7° - .040" & 1/16 "	9, 20
2	AK-2	1 Short Back Cap 3 Collets - .040", 1/16 ", 3/32 " 3 Collet Bodies - .040" & 1/16 ", 3/32 " 3 Alumina Nozzles - #4, #5, #6 3 E3° Tungsten - .040", 1/16 ", 3/32 "	1 Tapa trasera corta 3 Mordazas - .040", 1/16 ", 3/32 " 3 Portamordazas - .040" & 1/16 ", 3/32 " 3 Boquillas alumina - #4, #5, #6 3 E3° Tungsteno 7° - .040", 1/16 ", 3/32 "	17, 18, 26
3	AK-3	1 Short Back Cap 3 Collets- 1/16", 3/32", 1/8 " 3 Collet Bodies - 1/16", 3/32", 1/8 " 3 Alumina Nozzles - #5, #6, #8 3 E3° Tungsten 7° - 1/16", 3/32", 1/8 "	1 Tapa trasera corta 3 Mordazas - 1/16", 3/32", 1/8 " 3 Portamordazas - 1/16", 3/32", 1/8 " 3 Boquillas alumina- #5, #6, #8 3 E3° Tungsteno 7° - 1/16", 3/32", 1/8 "	17, 18, 26
4	AK-4	1 Long Back Cap 3 Collets - 1/16", 3/32", 1/8 " 3 Collet Bodies - 1/16", 3/32", 1/8 " 3 Alumina Nozzles - #5, #6, #7 3 E3° Tungsten 7° - 1/16", 3/32", 1/8 "	1 Tapa trasera larga 3 Mordazas - 1/16", 3/32", 1/8 " 3 Portamordazas - 1/16", 3/32", 1/8 " 3 Boquillas alumina - #5, #6, #7 3 E3° Tungsteno 7° - 1/16", 3/32", 1/8 "	9, 20
<b>Master Accessory Kits / Kits de accesorios Principal</b>				
5	MAK-1S	Back Caps 1-Short, 2-Medium, 1-Long Collets 2-.040", 4-1/16", 4-3/32", 2-1/8 " Collet Bodies 1-.040", 2-1/16", 2-3/32", 2-1/8 " Gas Lenses 1-.040", 1-1/16", 1-3/32", 1-1/8 " 2 Cup Gasket 4 O-rings for Back Caps 10 Wire Clamps	Tapa Trasera - 1 Corta, 2 Medianas, 1 larga Mordazas 2-.040", 4-1/16", 4-3/32", 2-1/8 " Portamordazas 1-.040", 2-1/16", 2-3/32", 2-1/8 " Gas Lenses 1-.040", 1-1/16", 1-3/32", 1-1/8 " 2 Aisladores 4 Anillos O para tapa trasera 10 Abrazaderas para la manguera	9, 20
6	MAK-2S	Back Caps 1-Short, 1-Long Collets 1-.040", 3-1/16", 3-3/32", 2-1/8", 1-5/32" Collet Bodies 1-.040", 2-1/16", 2-3/32", 2-1/8", 1-5/32" Gas Lenses 1-.040", 1-1/16", 1-3/32", 1-1/8 " 2 Cup Gasket 1 Gas Lens Insulator 4 O-rings for Back Caps	Tapa Trasera - 1 Corta, 1 larga Mordazas 2-.040", 4-1/16", 4-3/32", 2-1/8", 1-5/32" Portamordazas 1-.040", 2-1/16", 2-3/32", 2-1/8", 1-5/32" Gas Lenses 1-.040", 1-1/16", 1-3/32", 1-1/8 " 2 Aisladores 1 Aislador (Gas Lens) 4 Anillos O para tapa trasera	17, 18, 26



#	Part#	Description	Descripción	Length Longitud	Torches Antorchas
<b>Air-cooled Power Cables / Cables de alimentación refrigerados por aire</b>					
1	57Y01R	1 Piece Rubber	1 pieza de goma	12.5'	9, 17, 24FMT, 150M
	57Y03R	1 Piece Rubber	1 pieza de goma	25'	
	57Y03R-50	1 Piece Rubber	1 pieza de goma	50'	
2	57Y01BR	Nylon Braided Rubber	Goma trenzado de nylon	12.5'	
	57Y03BR	Nylon Braided Rubber	Goma trenzado de nylon	25'	
3	57Y01-2	2 Piece Cable	Cable de 2 piezas	12.5'	
	57Y03-2	2 Piece Cable	Cable de 2 piezas	25'	
	57Y03-2-50	2 Piece Cable	Cable de 2 piezas	50'	
4	46V28-R	1 Piece Rubber	1 pieza de goma	12.5'	26, 200M
	46V30-R	1 Piece Rubber	1 pieza de goma	25'	
	46V30R-50	1 Piece Rubber	1 pieza de goma	50'	
5	46V28BR	Nylon Braided Rubber	Goma trenzado de nylon	12.5'	
	46V30BR	Nylon Braided Rubber	Goma trenzado de nylon	25'	
6	46V28-2	2 Piece Cable	Cable de 2 piezas	12.5'	
	46V30-2	2 Piece Cable	Cable de 2 piezas	25'	
7	56Y38R	1 Piece Rubber	1 pieza de goma	12.5'	24
	56Y97R	1 Piece Rubber	1 pieza de goma	25'	
<b>Water-cooled Power Cables / Cables de alimentación refrigerados por agua</b>					
5	45V03	Vinyl	Vinilo	12.5'	20, 24W, 225M, 22A, 22B, 25
	45V04	Vinyl	Vinilo	25'	
9	45V03R	Nylon Braided Rubber	Goma trenzado de nylon	12.5'	
	45V04R	Nylon Braided Rubber	Goma trenzado de nylon	25'	
10	40V64	Vinyl	Vinilo	12.5'	18
	41V29	Vinyl	Vinilo	25'	
6	40V64R	Rubber	Goma	12.5'	
	41V29R	Rubber	Goma	25'	
12	40V64BR	Nylon Braided Rubber	Goma trenzado de nylon	12.5'	
	41V29BR	Nylon Braided Rubber	Goma trenzado de nylon	25'	
13	40V64P	Rubber	Goma	12.5'	18P
	41V29P	Rubber	Goma	25'	
14	40V84R	Rubber	Goma	12.5'	12, 27A, 27B
	40V84RL	Rubber	Goma	25'	
15	40V84R-3	Rubber	Goma	3'	
<b>Water Hose / Mangueras de agua</b>					
8	45V07	Vinyl	Vinilo	12.5'	20,
	45V08	Vinyl	Vinilo	25'	
17	45V07R	Nylon Braided Rubber	Goma trenzado de nylon	12.5'	
	45V08R	Nylon Braided Rubber	Goma trenzado de nylon	25'	
18	45V07M	Vinyl	Vinilo	12.5'	20F,
	45V08M	Vinyl	Vinilo	25'	
19	45V07RM	Nylon Braided Rubber	Goma trenzado de nylon	12.5'	
	45V08RM	Nylon Braided Rubber	Goma trenzado de nylon	25'	
20	40V74	Vinyl	Vinilo	12.5'	18, 18P
	41V32	Vinyl	Vinilo	25'	
21	40V74R	Nylon Braided Rubber	Goma trenzado de nylon	12.5'	
	41V32R	Nylon Braided Rubber	Goma trenzado de nylon	25'	
22	40V83R	Rubber	Goma	12.5'	12, 27
	40V83RL	Rubber	Goma	25'	
22	40V83R-3	Rubber	Goma	3'	
<b>Gas Hose / Mangueras de gas</b>					
23	45V09	Vinyl	Vinilo	12.5'	20,
	45V10	Vinyl	Vinilo	25'	
24	45V09R	Nylon Braided Rubber	Goma trenzado de nylon	12.5'	
	45V10R	Nylon Braided Rubber	Goma trenzado de nylon	25'	
25	40V75	Vinyl	Vinilo	12.5'	18, 18P
	41V30	Vinyl	Vinilo	25'	
26	40V75R	Nylon Braided Rubber	Goma trenzado de nylon	12.5'	
	41V30R	Nylon Braided Rubber	Goma trenzado de nylon	25'	
27	40V82R	Rubber	Goma	12.5'	12, 27
	40V82RL	Rubber	Goma	25'	
	40V82R-3	Rubber	Goma	3'	

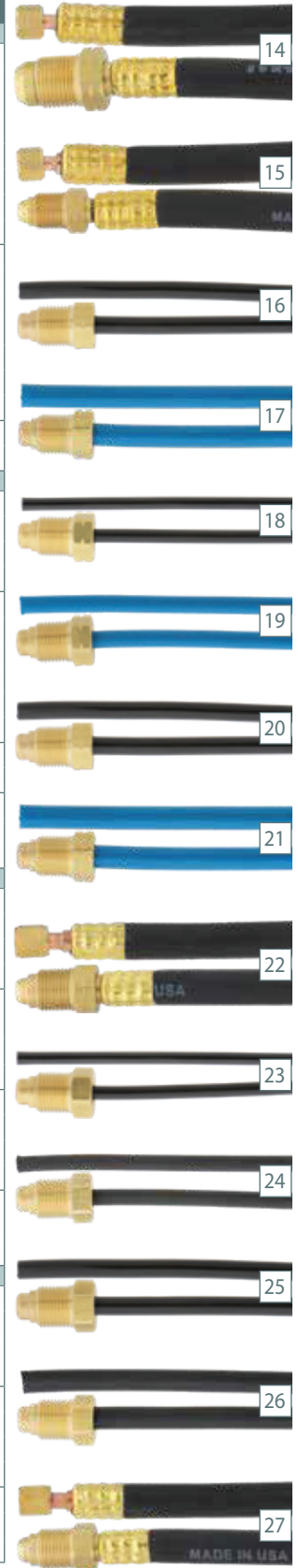





#	Part #	Description	Descripción
1	EK-1-25-R	Water-Cooled Extension Kit, 25' Rubber	Kit de Extensión, enfriado por agua, 25' goma
Each Kit Includes one of each / Cada kit incluye una de cada una			
	40V78LR	25' Power Cable Extension	Extensión de cable de alimentación
	40V76LR	25' Water Hose	25' Manguera de agua
	40V77LR	25' Gas Hose	25' Manguera de gas
	11N19	Power Cable Coupler	Acoplador de cable de alimentación
	11N18	Water Hose Coupler	Acoplador de la manguera de agua
	11N17	Gas Hose Coupler	Acoplador de la manguera de gas
	11N19IS	Insulator Sleeve	Manguito del aislador
2	EK-1-25	Water-Cooled Extension Kit, 25' Vinyl	Kit de Extensión, enfriado por agua, 25' vinilo
Each Kit Includes one of each / Cada kit incluye una de cada una			
	40V78L	25' Power Cable Extension	Extensión de cable de alimentación
	40V76L	25' Water Hose	25' Manguera de agua
	40V77L	25' Gas Hose	25' Manguera de gas
	11N19	Power Cable Coupler	Acoplador de cable de alimentación
	11N18	Water Hose Coupler	Acoplador de la manguera de agua
	11N17	Gas Hose Coupler	Acoplador de la manguera de gas
	11N19IS	Insulator Sleeve	Manguito del aislador
3	EK-2-25-R	Air-Cooled Extension Kit, 25' Rubber	Kit de Extensión, enfriado por aire, 25' goma
Each Kit Includes one of each / Cada kit incluye una de cada una			
	57Y03-R	25' Power Cable	25' Cable de alimentación
	430A	Power Cable Coupler	Acoplador de cable de alimentación
	430AIS	Insulator Sleeve	Manguito del aislador
4	EK-26-25-R	Air-Cooled Extension Kit, 25' Rubber	Kit de Extensión, enfriado por aire, 25' goma
Each Kit Includes one of each / Cada kit incluye una de cada una			
	46V30EK-R	25' Power Cable Extension	25' Extensión de cable de alimentación
	11N20	Power Cable Coupler	Acoplador de cable de alimentación
	11N19IS	Insulator Sleeve	Manguito del aislador

#	Part #	Description	Descripción	1	2	3
1	HK-1	Water-Cooled Hook-up Kit, 12.5' Vinyl	Kit para conjuntos, enfriado por agua, 12.5' vinilo			
Each Kit Includes   Cada kit incluye						
	40V76	2- 12.5' Water Hoses	2- 12.5' Manguera de agua			
	40V77	1- 12.5' Gas Hose	1- 12.5' Manguera de gas			
	45V11	1- Power Cable Adapter	1- Adaptador para cable de alimentación			
	11N18	1- Water Hose Coupler	1- Acoplador de la manguera de agua			
	A405	2- Water Adapters	2- Adaptador para agua			
2	HK-2	Air-Cooled Hook-up Kit, 12.5' Vinyl	Kit para conjuntos, enfriado por aire, 12.5' vinilo			
Each Kit Includes   Cada kit incluye						
	40V77	1- 12.5' Gas Hose	1- 12.5' Manguera de gas			
	11N17	1- Gas Hose Coupler	1- Acoplador de la manguera de gas			
3	HK-3	Air-Cooled Hook-up Kit, 12.5' Vinyl	Kit para conjuntos, enfriado por aire, 12.5' vinilo			
Each Kit Includes   Cada kit incluye						
	40V77	1- 12.5' Gas Hose	1- 12.5' Manguera de gas			
	40V77-18	1- 18" Gas Hose	1- 18" Manguera de gas			





#	Part#	Description	Descripción	Length Longitud	Torches Antorchas
Air-cooled Extension Power Cables / Cables de extensión dev energía, refrigerado por aire					
1	46V30EK-R	1 Piece Rubber	1 pieza de goma	25'	26
Water-cooled Extension Power Cables / Cables de extensión de energía, refrigerado por agua					
2	40V78	Vinyl	Vinilo	12.5'	All Water- cooled
	40V78L	Vinyl	Vinilo	25'	
3	40V78R	Rubber	Goma	12.5'	All Water- cooled
	40V78L R	Rubber	Goma	25'	
Water Hose Extensions/ Extensiones de mangueras de agua					
4	40V76-10	Vinyl	Vinilo	10'	All Water- cooled
	40V76	Vinyl	Vinilo	12.5'	
	40V76L	Vinyl	Vinilo	25'	
5	40V76R	Rubber	Goma	12.5'	All Water- cooled
	40V76LR	Rubber	Goma	25'	
Gas Hose Extensions / Extensiones de mangueras de gas					
6	40V77-18	Vinyl	Vinilo	18"	All Water- cooled
	40V77-10	Vinyl	Vinilo	10'	
	40V77	Vinyl	Vinilo	12.5'	
	40V77L	Vinyl	Vinilo	25'	
	40V77L-50	Vinyl	Vinilo	50'	
7	40V77R	Rubber	Goma	12.5'	All Water- cooled
	40V77LR	Rubber	Goma	25'	



**For Stud Machine Without Gas Solenoid Torch with Valve, 1 Piece Power Cable**  
 Para maquinas sin solenoid de gas y montages terminales Antorcha con válvula, cable de alimentación una pieza

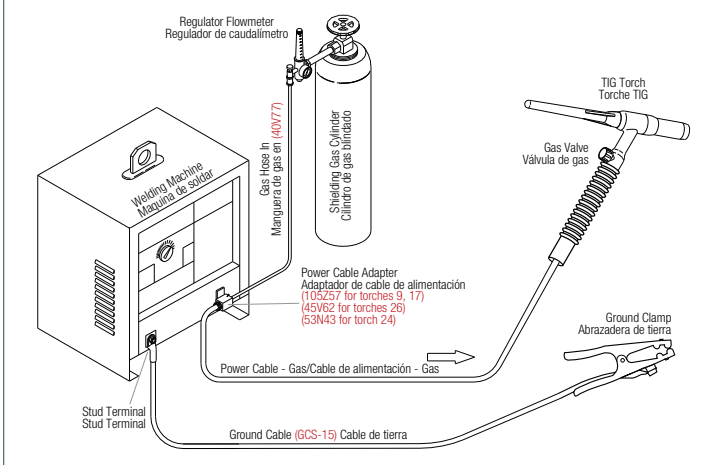

**For Machine With Dinse Connector without Gas Solenoid Torch with Valve, 1 Piece Power Cable**  
 Para maquinas sin solenoid de gas y montages usando conectores Dinse Antorcha con válvula, cable de alimentación una pieza

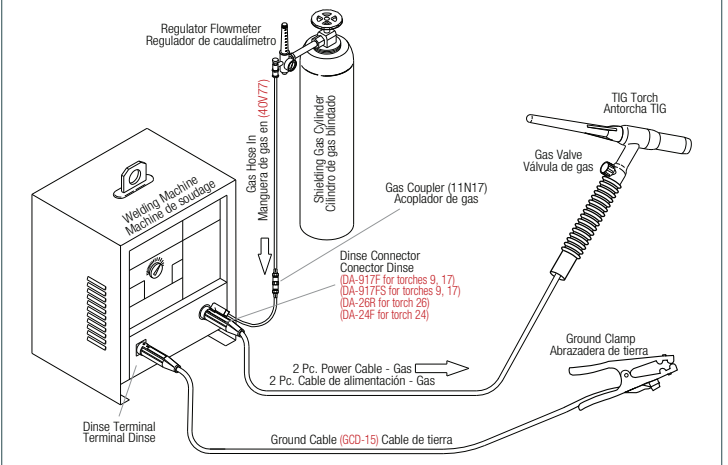

**For Stud Machine Without Gas Solenoid Torch with Valve, 2 Piece Power Cable**  
 Para maquinas sin solenoid de gas y montages terminales Antorcha con válvula, cable de alimentación dos piezas

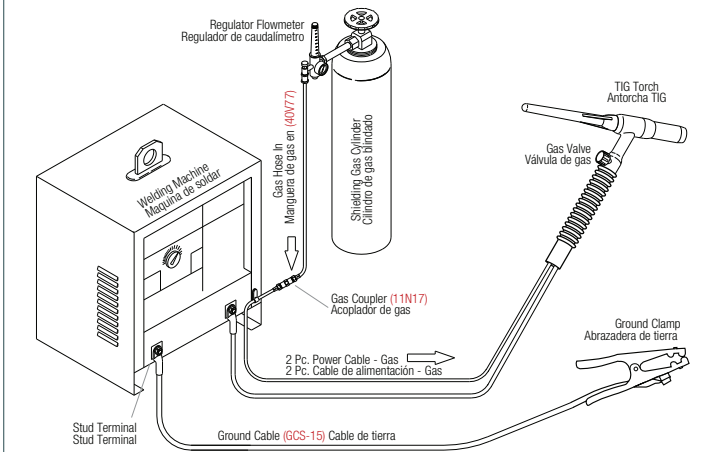

**For Machine With Dinse Connector Without Gas Solenoid Torch with Valve, 2 Piece Power Cable**  
 Para maquinas sin solenoid de gas y montages usando conectores dinse Antorcha con válvula, cable de alimentación dos piezas

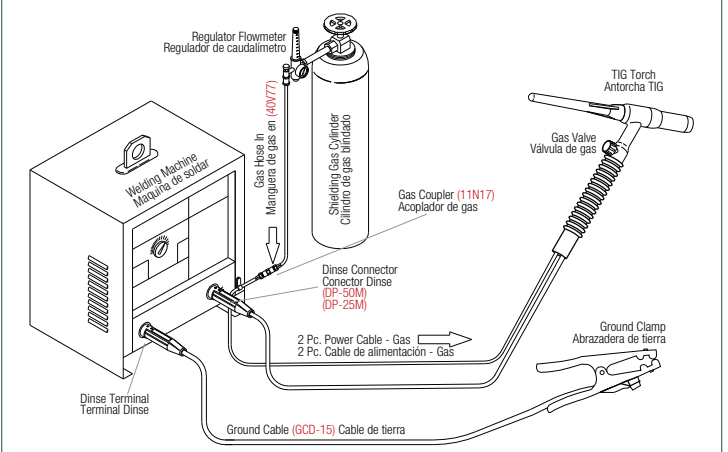

**For Stud Machine With Gas Solenoid Torch without Valve, 1 Piece Power Cable**  
 Para maquinas con solenoid de gas y montages terminales Antorcha sin válvula, cable de alimentación una pieza

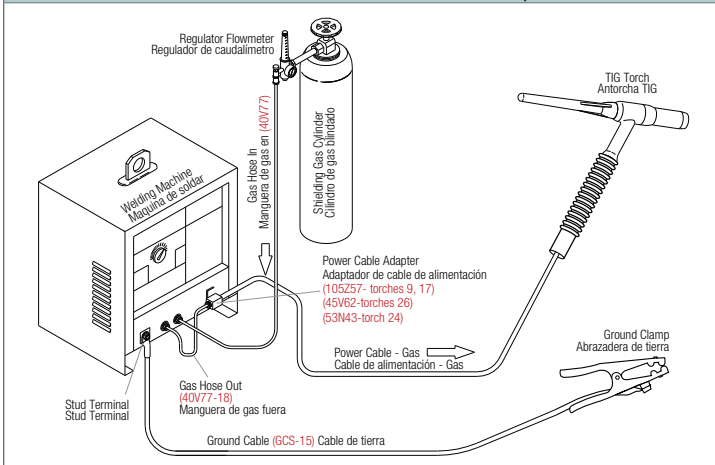

**For Machine Equipped With In-line Dinse Connector Torch without Valve, 1 Piece Power Cable**  
 Para maquinas con solenoid de gas y conectores Dinse para del pase flujo, Antorcha sin válvula, cable de alimentación una pieza

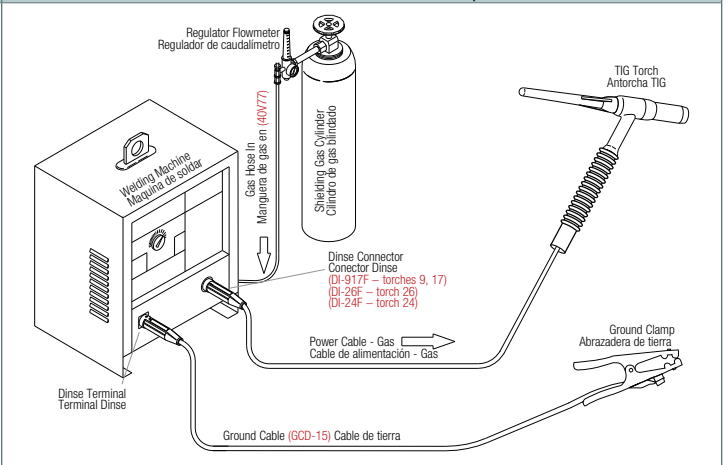

**For Stud Machine With Gas Solenoid Torch without Valve, 2 Piece Power Cable**  
**Para maquinas con solenoid de gas y montajes terminales**  
**Antorcha sin válvula cable de alimentación dos piezas**

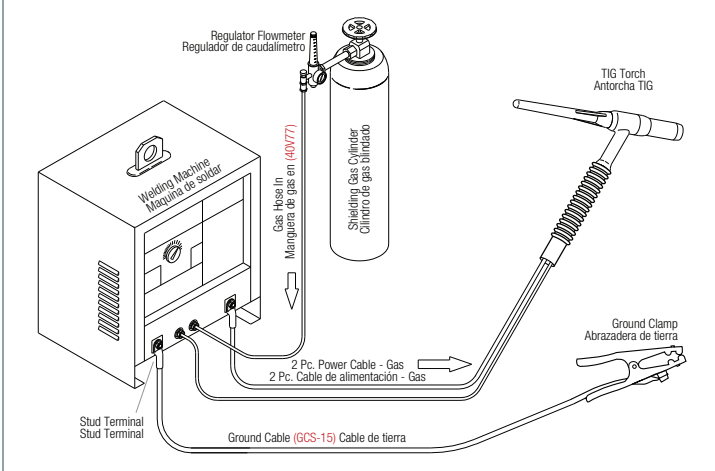

**For Machine With Dinse Connector & Gas Solenoid Torch without Valve, 2 Piece Power Cable**  
**Para maquinas con solenoid de gas y montajes usando conectores dinse**  
**Antorcha sin válvula cable de alimentación dos piezas**

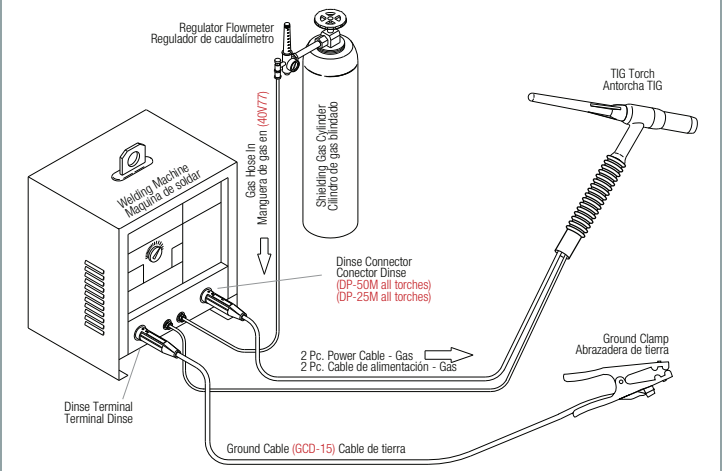

**For Stud Machines With Gas Solenoid With Water Cooler**  
**Para maquinas con solenoid de gas y montajes terminales**  
**Con refrigerador del agua**

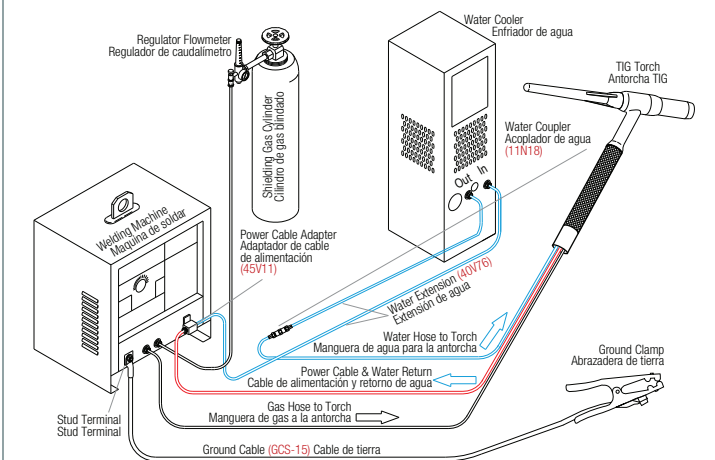

**For Machines with Dinse Connectors and Gas Solenoid With Water Cooler**  
**Para maquinas con solenoid de gas y conectores Dinse con enfriamiento por agua**  
**Con refrigerador del agua**

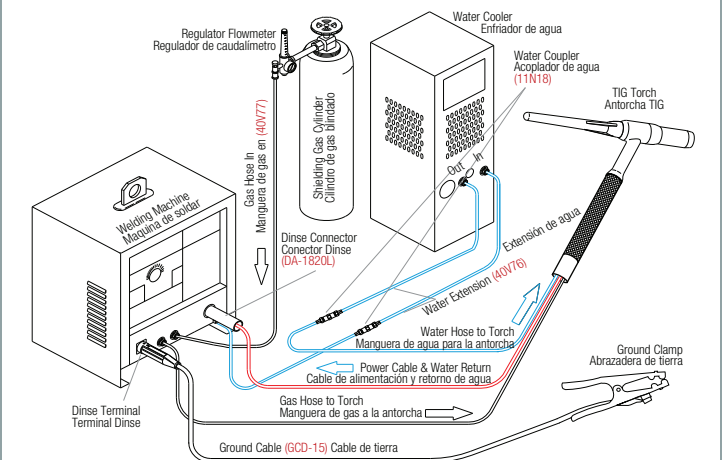

**For Stud Machines With Gas Solenoid Using City Water**  
**Para maquinas con solenoid de gas y montajes terminales**  
**Usando agua de la ciudad**

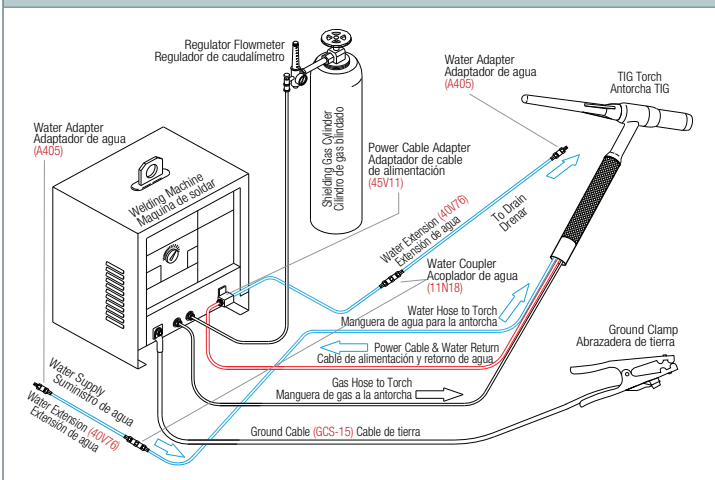

**For Machines with Dinse Connectors and Gas Solenoid Using City water**  
**Para maquinas con solenoid de gas y conectores Dinse**  
**Usando agua de la ciudad**

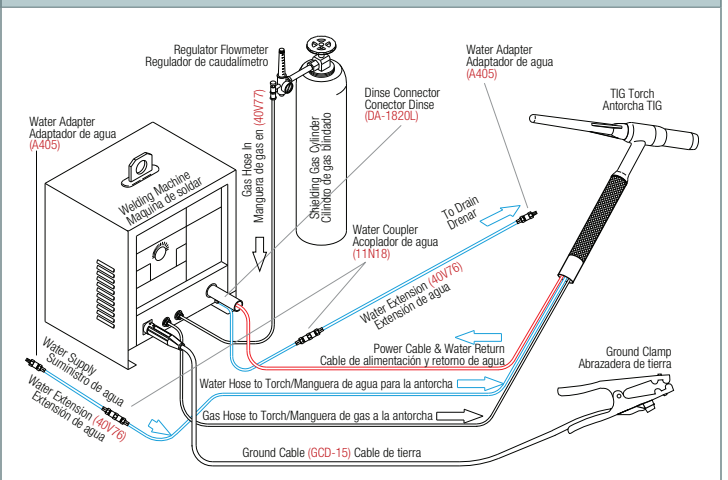



# BRIGHTON-BEST INTERNATIONAL

## Global Headquarters

**Tainan, Taiwan**  
No.122, Yi-Lin Road,  
Rende Township,  
Tainan, 71752 Taiwan  
Tel. 886-6-270-1756

## USA Headquarters

**Long Beach, California**  
5855 Obispo Ave.  
Long Beach, CA 90805  
Tel. 562-808-8000  
Fax: 562-808-8137

## U.S.A.

**Atlanta, GA**  
250 Horizon Dr.  
Suwanee, GA 30024  
Tel. 678-459-3700  
Fax: 678-459-3720  
WATS: 800-275-0056  
atlanta@brightonbest.com

**Boston, MA**  
928 West Chestnut St.  
Brockton MA 02301  
Tel. 508-857-2808  
Fax: 774-296-8685  
WATS: 800-275-0037  
boston@brightonbest.com

**Charlotte, NC**  
8604 Cliff Cameron Dr., Ste. 154  
Charlotte, NC 28269  
Tel. 704-393-6711  
Fax: 704-393-6715  
WATS: 800-275-0050  
charlotte@brightonbest.com

**Chicago, IL**  
940 North Enterprise St.  
Aurora, IL 60504  
Tel. 630-898-9600  
Fax: 630-898-9601  
WATS: 800-929-2378  
chicago@brightonbest.com

**Cleveland, OH**  
21855 Commerce Pkwy.  
Strongsville, OH 44149  
Tel. 440-238-1350  
Fax: 440-238-2336  
WATS: 800-275-0048  
cleveland@brightonbest.com

**Dallas, TX**  
3225 Roy Orr Blvd., Ste. 200  
Grand Prairie, TX 75050  
Tel. 972-790-1201  
Fax: 972-790-6265  
WATS: 800-275-0054  
dallas@brightonbest.com

**Denver, CO**  
9700 E. 56th Ave., Unit 120  
Denver, CO 80238  
Tel. 303-576-0530  
Fax: 303-371-9775  
WATS: 800-935-2202  
denver@brightonbest.com

**Detroit, MI**  
6060 Stoney View Drive, Ste. 100  
Shelby Township, MI 48316  
Tel. 586-412-3350  
Fax: 586-412-3305  
WATS: 800-275-0046  
detroit@brightonbest.com

**Houston, TX**  
6911 Fairbanks N. Houston Rd. Ste. 150  
Houston, TX 77040  
Tel: 713-466-0336  
Fax: 713-466-0385  
WATS: 800-275-0054  
houston@brightonbest.com

**Los Angeles, CA**  
12801 Leffingwell Ave.  
Santa Fe Springs, CA 90670  
Tel. 562-483-2740  
Fax: 562-404-3999  
WATS: 800-275-0028  
losangeles@brightonbest.com

**Miami, FL**  
3426 West 84th St., Ste. 203  
Hialeah, FL 33018  
Tel. 305-512-3446  
Fax: 305-512-3450  
WATS: 800-275-0035  
miami@brightonbest.com

**Nashville, TN**  
446 Metroplex Dr., Ste. A120  
Nashville, TN 37211  
Tel. 615-834-1154  
Fax: 615-834-1157  
WATS: 800-275-0029  
nashville@brightonbest.com

**Portland, OR**  
13440 NE Jarrett St.  
Portland, OR 97230  
Tel: 503-261-0660  
Fax: 503-252-4093  
WATS: 800-275-0686  
portland@brightonbest.com

**Minneapolis, MN**  
21010 Commerce Blvd.  
Ste. B  
Rogers, MN 55374  
Tel. 763-425-9464  
Fax: 763-425-9266  
WATS: 800-275-0031  
minnesota@brightonbest.com

**Salt Lake City, UT**  
2179 S. Commerce Center Dr. Ste. 400  
West Valley City, UT 84120  
Tel: 801-972-1313  
Fax: 801-972-5114  
WATS: 800-935-1402  
saltlake@brightonbest.com

**Sayreville, NJ**  
200 Kennedy Dr.  
Sayreville, NJ. 08872  
Tel. 732-525-8400  
Fax: 732-525-8408  
sayreville@brightonbest.com

**Seattle, WA**  
20308 59th Place South, Bldg. 1A  
Kent, WA, 98032  
Tel. 253-872-3417  
Fax: 253-872-3415  
WATS: 800-935-1502  
seattle@brightonbest.com

**St. Louis, MO**  
1856 Craig Rd.  
St. Louis, MO 63146  
Tel. 314-205-8001  
Fax: 314-205-0857  
WATS: 800-275-0047  
stlouis@brightonbest.com

**Tampa, FL**  
4915 Distribution Dr.  
Tampa, FL 33605  
Tel. 305-512-3446  
Fax: 305-512-3450  
WATS: 800-275-0035  
tampa@brightonbest.com

**West Deptford, NJ**  
1222 Forest Parkway  
West Deptford, NJ. 08066  
Tel. 856-241-9494  
Fax: 856-241-9477  
WATS: 800-935-2378  
sayreville@brightonbest.com

**IRONCLAD HQ**  
Dallas, TX  
3325 Roy Orr Blvd., Ste. 200  
Grand Prairie, TX. 75050  
Tel. 972-996-5664  
Fax: 469-341-7213  
Toll Free: 844-200-5664  
customerservice@ironclad.com

## CANADA

**Montreal, Québec**  
12000 Cavendish  
Saint-Laurent, Québec H4R 1Y2  
Tel: 514-336-9888  
Fax: 514-336-8865  
WATS: 800-361-2076  
montreal@brightonbest.com

**Toronto, Ontario**  
7900 Goreway Dr., Unit 1  
Brampton, Ontario L6T 5W6  
Tel: 905-791-2000  
Fax: 905-791-6841  
WATS: 800-268-6918  
toronto@brightonbest.com

**Vancouver, British Columbia**  
9489 200 St, Unit 103&104  
Langley, B.C. V1M 3A7  
Tel: 604-513-0311  
Fax: 604-513-0312  
WATS: 800-663-9106  
vancouver@brightonbest.com

## MEXICO

**Mexico**  
Toll Free: 1(855)-816-9726  
Fax: 562-404-3999  
mexico@brightonbest.com

## AUSTRALIA

**Brisbane, Queensland**  
11 Stradbroke St.  
Heathwood, Queensland 4110  
Tel. 617-3727-5700  
Fax: 617-3714-9821  
qldsales@brightonbest.com.au

**Melbourne, Victoria**  
31-33 Canterbury Rd.  
Braeside, VIC 3195  
Tel. 613-8586-0244  
Fax: 613-9587-7255  
vicsales@brightonbest.com.au

**Perth, Western Australia**  
Unit 3/420 Victoria Rd.  
Malaga, Western Australia 6090  
Tel. 618-6240-6800  
Fax: 618-9248-4766  
wasales@brightonbest.com.au

**Sydney, New South Wales**  
1 Wonderland Dr.,  
Eastern Creek, NSW 2766  
Tel. 612-8818-0900  
Fax: 612-9620-1050  
nswsales@brightonbest.com.au

## NEW ZEALAND

**Auckland, New Zealand**  
28B Pavillion Dr. Airport Oaks  
Mangere, Auckland 2022  
Tel. 649-257-5256  
Fax: 649-257-5328  
nzsales@brightonbest.co.nz

## U.K.

**Birmingham, West Midlands**  
Fastener Complex D1  
Cradley Business Park,  
Overend Rd., Cradley Heath  
West Midlands B64 7DW  
Tel. +44 (0) 1384-568144  
Fax: +44 (0) 1384-413719  
sales@brightonbest.org

## BRAZIL

**São Paulo, Brazil**  
Rua Dos Missionários, 410  
São Paulo, Brazil 04729-001  
Tel. 55 11-5641-4037  
Fax: 55 11-5641-2444  
luizab@brightonbest.com.br